

Rack mounted meter *alpha A2500*

Product manual

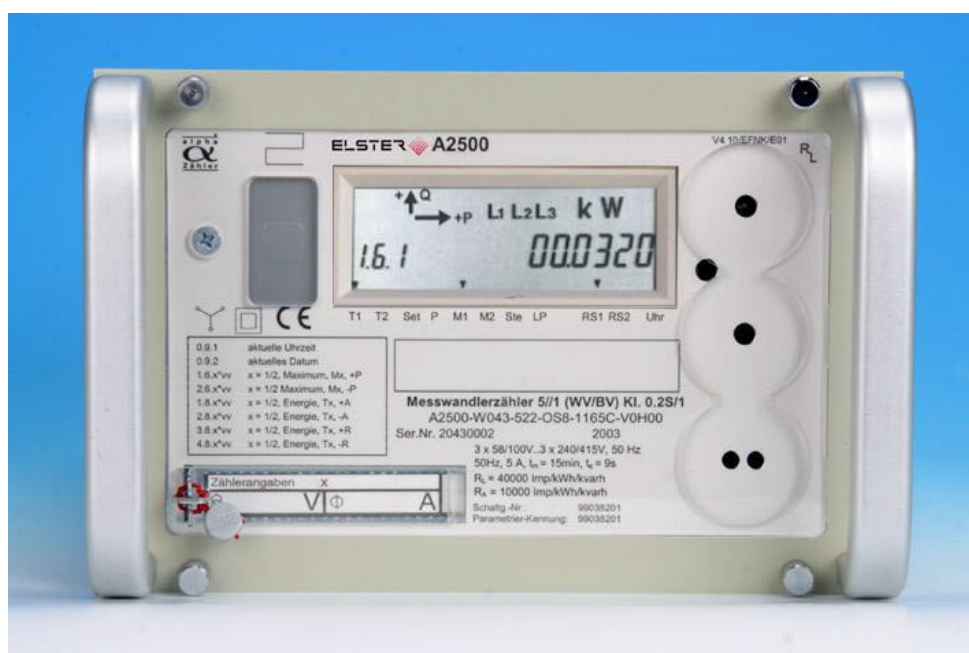

Document name
 Document number:
 Date of version:

A2500_PR_E.doc
 1KGL 922700 V002D, Revision 1.1
 11.11.2003

COPYRIGHT NOTICE

Copyright © 2003 by ELSTER Messtechnik GmbH. All rights are reserved.

No part of this document may be reproduced, transmitted, processed or recorded by any means or form, electronic, mechanical, photographic or otherwise, translated to another language, or be released to any third party without the express written consent of ELSTER Messtechnik GmbH.

Printed in Germany

NOTICE

The information contained in this document is subject to change without notice.

ELSTER shall not be liable for errors contained herein or for incidental or consequential damages in connection with the furnishing, performance, or use of this material.

ELSTER expressly disclaims all responsibility and liability for the installation, use, performance, maintenance and support of third party products. Customers are advised to make their own independent evaluation of such products.

Content

1	Overview	6
1.1	System overview	6
2	Referenced Documents	6
3	Application	7
3.1	Essential features of the alpha meter A2500.....	7
3.1.1	High accuracy.....	7
3.1.2	Configuration.....	7
3.1.3	Integrated load profile.....	7
3.1.4	Wide range meter.....	7
3.1.5	3-wire / 4-wire applications	7
3.1.6	New meter standards	7
4	Description of the device	8
4.1	Design features	8
4.2	Power supply	8
4.2.1	Auxiliary power supply	8
4.3	Model variants	9
4.3.1	CT connected meter (3- or 4-wires), 50Hz	9
4.3.2	CT connected meter (3-wires, according Aaron-type), 50Hz	9
4.3.3	CT connected meter (2-wires), 16.66Hz or 50Hz	9
5	Measured value acquisition	10
5.1	Measuring module	10
5.2	Measuring principle.....	11
5.2.1	Vectored Method	11
5.2.2	Phase shift method.....	11
6	Display Control	12
6.1	Display	12
6.2	Display Modes	15
6.3	Scroll mode.....	16
6.4	Display test mode.....	16
6.5	A-button menu	16
6.5.1	Standard mode (Menu Option "Std-dAtA")	16
6.5.2	Second Standard mode (Menu Option "Abl-dAtA")	17
6.5.3	Load profile mode (Menu option „P.01“)	17
6.5.3.1	Date selection for the day block.....	17
6.5.3.2	Load profile values of the selected day	17
6.6	R-button menu.....	17
6.6.1	Setting mode (Menu option „Set“)	18
6.6.1.1	Setting date and time with pushbutton control	18
6.6.1.2	Set of energy/demand tariff source by using alternate and demand reset button..	18
6.6.2	High resolution mode for test purposes (Menu option „tEst“)	18
6.7	Set of time and date.....	19
6.7.1	Set of time and day through communication interface	19
6.7.2	Set of time and date by using DCF77 antenna.....	19
6.7.3	Set of time and date by using the alternate and demand reset button.....	19
6.8	Flow chart of different display modes	20
6.9	Demand reset.....	23
7	Identifier system	24
7.1	Standard data readout list.....	24
7.2	Service list - second data readout list	25

7.3	OBIS formatted read and write operations.....	25
8	Tariff characteristics	26
8.1	General remarks	26
8.2	Energy tariff control.....	26
8.3	Maximum demand tariff control.....	26
8.3.1	Active- reactive- and apparent demand measurement	27
8.3.2	Control options for demand tariff information.....	27
8.3.3	Synchronization of the demand period.....	28
8.4	Energy and demand tariff sources	29
8.5	Oversetting of the internal tariff source.....	29
8.6	Delta register values	29
8.7	Real time clock.....	30
8.7.1	General characteristics of the real time clock.....	30
8.7.2	Battery characteristic.....	30
8.7.3	Correction the device clock.....	31
8.7.3.1	Correction the device clock with „integration period end“	31
8.7.3.2	Correction the device clock on a minute base.....	31
8.7.3.3	Correction the device clock daily	31
8.7.4	Internal tariff clock	32
9	Load profile of billing data	33
9.1.1	Features of the load profile storage	33
9.1.2	Depiction of load profile in the data telegram	34
9.1.3	Load profile readout by using R5 / R6 - command.....	35
10	Setting parameters.....	36
11	Inputs / Outputs	38
11.1	Interfaces	38
11.1.1	Optical interface.....	38
11.1.2	CL0-interface	38
11.1.3	RS232-C interface.....	38
11.1.4	RS485-inteface.....	38
11.1.5	Use „without baud rate changeover“	40
11.1.6	Separate data readout lists	40
11.2	Control inputs	40
11.3	Synchronization input by using the DFC77- antenna.....	40
11.4	Mechanical control output.....	40
11.5	Electronic outputs	41
11.5.1	Electronic control outputs	41
11.5.2	Electronic pulse outputs	41
11.6	Overload Control.....	42
11.7	Electronic pulse inputs.....	42
11.8	Auxiliary power supply	42
12	Security functions	43
12.1	Error messages	43
12.2	Error messages according VDEW-specification	43
12.2.1	Certification relevant alarms.....	43
12.2.2	Non Certification relevant alarms	44
12.2.3	Diagnostic messages	44
12.3	Log file.....	45
12.3.1	Characteristic of the log file	45
12.3.2	Certified log file	45
12.3.3	Log file format	45
12.3.4	Depiction of a logfile in the data telegram.....	46
12.3.5	Readout modes of the log file by using R5 / R6 - commands	47

12.4	Events of of standard register data list.....	47
12.5	Data integrity	48
12.6	Password protection	48
12.7	Display of meter status information's	49
12.8	Meter reprogramming security	50
13	Instrumentation measurement.....	51
13.1	Instantaneous network parameters.....	51
13.2	Profile of instrumentation parameters	52
14	Calibration and test.....	53
14.1	Calibration	53
14.2	Certification of the meter.....	53
14.3	Manufacturer specific test mode	53
14.4	Simplified test mode	53
14.5	Simple creep and anti-creep test.....	54
14.6	Manual test mode	54
14.7	Checksum display.....	54
15	User program	55
15.1	Reading and configuration tool <i>alphaset</i>	55
16	Enclosure	56
16.1	Outside dimensions	57
16.2	Example of connection diagram	58
17	Installation and start-up.....	59
17.1	General function monitoring.....	59
17.2	Checking the display	60
17.3	Installation comment.....	61
17.3.1	Fuse protection	61
17.3.2	Auxiliary power supply connection	61
18	Type key.....	62
19	Name plate.....	64
20	Technical data of the A2500	65
21	Appendix.....	66
21.1	Parameter of the display and data readout list	66
21.2	Connection diagrams.....	72

1 Overview

1.1 System overview

The document describes the basic features of *alpha* meter A2500 including information's about:

- application
- basic description of the meters
- Data acquisition
- Control and displays
- Identifier System
- Tariff structure
- Setting parameters
- Inputs / Outputs
- Security features
- Calibration and test
- User tools for reading and configuring of the meter
- Installation and start-up

2 Referenced Documents

Title	Version	Date
VDEW Lastenheftes V2.0	V2.0	12.97
Zählerstandsübertragung, Tarif- und Laststeuerung; Datenübertragung für festen und mobilen Anschluß	DIN EN 61107	08.96
Messung der elektrischen Energie; Zählerstands- übertragung, Tarif- und Laststeuerung OBIS – Object Identification System	EN 62056-61	06.02
Elektrizitätszähler in Isolierstoffgehäusen für unmittelbaren Anschluß bis 60 A Grenzstrom; Hauptmaße für Drehstromzähler	DIN 43857 Teil 2	09.78

3 Application

With the deregulation of the energy market, in combination with a changing cost situation, new flexible tariff structures and a modern energy management are required. Remote metering and the standardization process become more and more important. With the *alpha* meter A2500, designed as a rack mounted meter for high precision measurements, ELSTER has created the conditions to match these new requirements.

The *alpha* Meter is produced in several different variants for direct and current transformer connection. The meter conforms to the relevant specifications of the DIN and IEC standards, and complies with the recommendations of VDEW Lastenheftes V2. VDEW Specification V2.0 for electronic meters.

3.1 Essential features of the alpha meter A2500

3.1.1 High accuracy

Digital measured-value processing with a digital signal processor (DSP) and high sample rate for accurate, flexible measured-value processing in all 4 quadrants.

3.1.2 Configuration

User-friendly readout and parameterizing tool *alphaSet*, enabling users to define their own different function variants.

3.1.3 Integrated load profile

With the integrated load profile and various electrical interfaces, like the 20mA current loop, RS232 or RS485 interface the meter can easily be connected to a AMR system without using additional data loggers.

3.1.4 Wide range meter

By using a wide range power supply the meter operate and measure in the range of 3x58/100V .. 3x240/415V. Furthermore the meter can be used for nominal current $I_n=1A$ and $I_n=5A$ Because of one meter for all voltage levels the customer can reduce his stock inventory.

3.1.5 3-wire / 4-wire applications

The same meter can be used for 3-wire or 4-wire applications and therefore the customer can reduce his stock inventory.

3.1.6 New meter standards

The A1500 fulfils the requirements of the following new meter standards for electronic meters

- VDEW Lastenheftes V2.,
- OBIS-identifier system, EN62056-61
- DIN EN 61107

4 Description of the device

4.1 Design features

The meter's dimensions and the attachment of the connection leads are as specified in DIN 43862. The meter is redrawable under power by using special Essailec connectors.

The electronics PCB is connected directly to the top of the housing, which itself is covered by a transparent lid. Underneath this transparent lid, which is secured in place by a lead seal from the power utility, is the reset button and the rating plate. The rating plate is secured to the top of the housing with a screw, above which the calibration label is affixed, so that the rating plate can be removed only by damaging the calibration label (see Fig. 17).

After the rating plate has been removed, the user has access to the parameterization button, a hardware feature designed to protect the meter against unauthorized parameterization.

4.2 Power supply

The meter's power supply is implemented using a wide range power supply (nominal voltages: 3x58/100V – 3x240/415V), i.e. if two phases fail, or one phase and the neutral conductor, the meter will remain fully functional. The customer advantages are:

- No problems with earth faults
- No damage of the meter by wrong connection during installation (change on ground and neutral)
- No damage of the meter during testing (connection of 3x230/400V instead of 58/100V)
- Same meter can be used for 3x58/100 to 3x240/415V applications

Optionally an auxiliary wide range power supply can be used from nominal voltages of 48-230V AC or DC (See chapter 11.8).

4.2.1 Auxiliary power supply

The meter can optionally be equipped with an auxiliary wide power supply. By using the external power supply the meter is powered by this supply. In case of loosing this supply voltage the meter will be powered by the measuring voltage.

The supply voltage for the external power supply is:

- 48V - 230V AC/DC nominal voltage, +/- 15%

4.3 Model variants

The *alpha* Meter is available in several different model variants. Because of his wide range power supply and his high measuring range the identical meter can be used for all voltage ranges, and for 3-wire and 4-wire applications.

4.3.1 CT connected meter (3- or 4-wires), 50Hz

- 3x58/100V .. 3x240/415V	5//1A, 1/2A, 5/6A, 5/15A	Class 1, 0,5S, 0,2S
- 3x240/415V	5//1A, 1/2A, 5/6A, 5/15A	Class 1, 0,5S, 0,2S
- 3x230/400V	5//1A, 1/2A, 5/6A, 5/15A	Class 1, 0,5S, 0,2S
- 3x58/100V	5//1A, 1/2A, 5/6A, 5/15A	Class 1, 0,5S, 0,2S
- 3x63/110V	5//1A, 1/2A, 5/6A, 5/15A	Class 1, 0,5S, 0,2S

4.3.2 CT connected meter (3-wires, according Aaron-type), 50Hz

- 3x100V .. 3x240V,	5//1A, 1/2A, 5/6A	Class 1, 0,5S, 0,2S
- 3x100V,	5//1A, 1/2A, 5/6A	Class 1, 0,5S, 0,2S
- 3x110V,	5//1A, 1/2A, 5/6A	Class 1, 0,5S, 0,2S
- 3x200V,	5//1A, 1/2A, 5/6A	Class 1, 0,5S, 0,2S
- 3x230V,	5//1A, 1/2A, 5/6A	Class 1, 0,5S, 0,2S
- 3x240V,	5//1A, 1/2A, 5/6A	Class 1, 0,5S, 0,2S

4.3.3 CT connected meter (2-wires), 16.66Hz or 50Hz

- 1x100V .. 3x240V	5//1A, 1/2A, 5/6A	Class 1, 0,5S
--------------------	-------------------	---------------

5 Measured value acquisition

5.1 Measuring module

The measuring module (Fig. 1) comprises current and voltage transformers plus a highly integrated customized circuit (ASIC). It has been developed specifically for the *alpha* Meter.

The analog measured variables obtained are digitized in the ASIC by a 21-bit A/D converter using the Sigma-Delta principle at a sample frequency of 2400 Hz, and fed to a downstream digital signal processor, which uses them to compute the active or reactive powers plus the corresponding energies, and forwards energy-proportional pulses to the tariff module. By using both digital multiplication and integration, significant advantages can be achieved in terms of measuring stability and flexibility.

The scanning frequency has been selected so as to ensure that the electrical energy contained in the harmonics is acquired with the specified class accuracy.

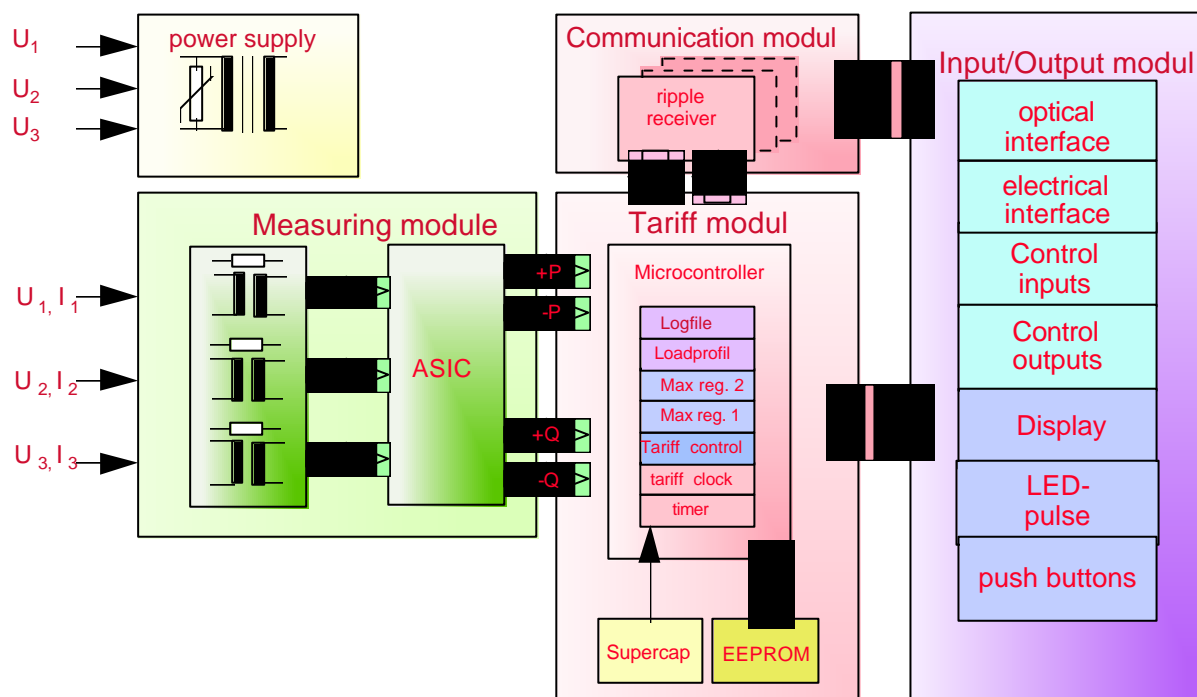

Fig. 1: Functional schematics of the *alpha* Meter

5.2 Measuring principle

The *alpha* Meter's basic hardware can be used to acquire the following measured variables:

- active power (+P),
- active power (-P),
- reactive power (Q1, Q2, Q3, Q4 individually or in combination)
- apparent power (+S, -S)

The active power is obtained by multiplying the current and voltages values in accordance with Equation (1):

$$p(t) = u(t) * i(t) \quad (1)$$

The *alpha* meter can calculate the reactive energy in 2 different ways:

5.2.1 Vectored Method

The *alpha* Meter can compute the reactive power using the vector method, i.e. the reactive power is obtained from the apparent and active power values using the following formula:

$$Q = \sqrt{S^2 - P^2} \quad (2)$$

$$\text{where } S = U_{\text{rms}} * I_{\text{rms}} \quad (3)$$

The apparent power can be obtained from the r.m.s values for current and voltage using Formula (2). Since the harmonic content in the two r.m.'s. values, and thus in the apparent and active power values, is also taken into account, the harmonic power values are also utilized when computing the reactive power.

5.2.2 Phase shift method

With this method a phase shift of 90° degree between voltage and current and a following multiplication of voltage and current according eq. 1 is implemented.

6 Display Control

6.1 Display

The LC display of the A2500 in accordance with VDEW Specification V2.0 is illustrated in Fig. 2:

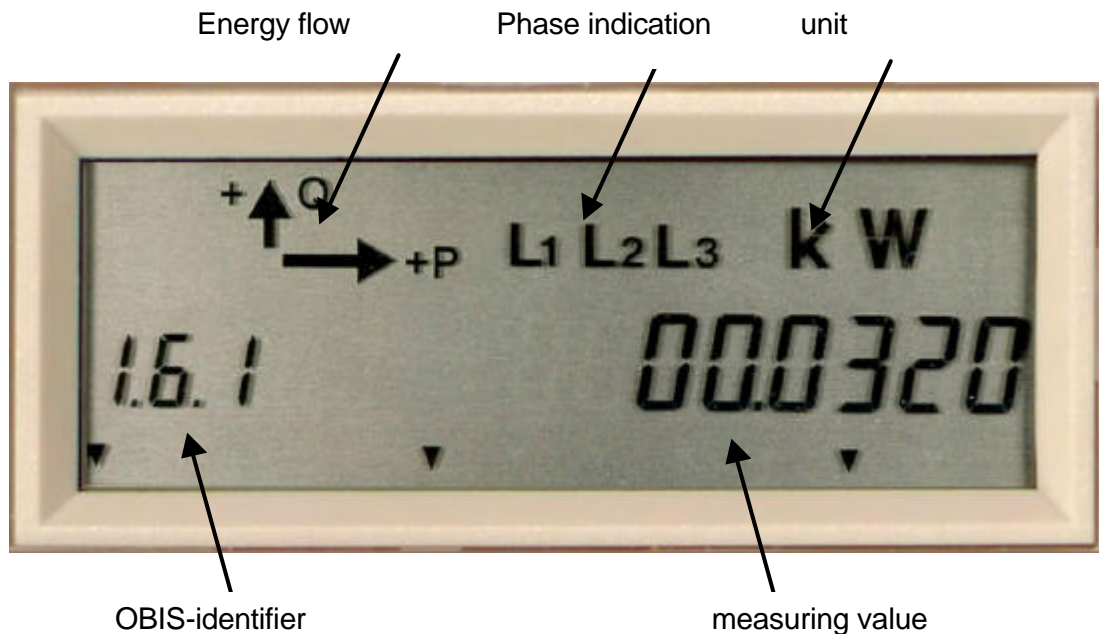

Fig. 2 LC display of the A2500 in conformity with VDEW Specification V2.0

Back lightened display

The display can optionally be back lightened to be readable under dark reading conditions. The back lightened display will be activated for 2 minutes by pressing the alternate or the demand reset button.

The display consists of the following items:

Operating display

The definitions for import and export of energy have been agreed in terms of the load reference arrow system (VZS). For defining the transmission direction of active and reactive power, the specifications of the load reference arrow system likewise apply. The VZS assumes that the power utility's contracting party is importing energy (+A) from the supply grid.

Display of activated tariff

The tariffs T1 to T4 and M1 to M4 switched on at any one time are continuously displayed. In addition, the following applies:

Arrow to the right:	Indicator for positive active power
Arrow to the left:	Indicator for negative active power
Arrow pointing upwards:	Indicator for positive reactive power
Arrow pointing downwards:	Indicator for negative reactive power

In the case of meters with an energy feature, the relevant symbols will flash when the "**electronic reversal disable**" is active. The symbols for the measured variable involved have been switched off if the power is below the device's start-up threshold.

Phase indication

The phase display indicates which phases are energized. The corresponding symbols are switched off if there is no voltage at the phase concerned. All active symbols will flash if the three phase voltages are not occurring in the sequence L1, L2 and L3.

Identifier and value range

All digits are separated by dots (OBIS separator or decimal point). Time particulars (h, min, sec) are separated by colons, date particulars (year, month, day) by the top dots of the colons.

Cursor field

The cursor field contains 12 element positions, and provides the assignments for operationally important status information located under the display. The cursors become visible when the assigned device status has materialized. In "**Parameterization mode**", all active cursors flash. The following abbreviations are used under cursor positions 1 to 12:

T1-T4	Tariff information for energy, all active registers are declared on the rating plate
M1-M4	Tariff information for power, all active registers are declared on the rating plate
RS1,RS2	The cursor concerned marks the alternating positions of an internal or external tariff mechanism. RS1 / RS2 is assigned to terminals MREa / MREb. The cursor concerned is activated when a voltage leads to a demand reset on the input terminal assigned, or if the output terminal assigned is exhibiting active state. The cursor activated will flash for as long as a reset disable has been activated.
CLK	The cursor is continuously switched on when the internal device clock is controlling the tariff mechanism. The cursor will flash if the running reserve of the device clock has been exhausted and the device clock has not then been set.
SET	The cursor is switched on when the meter is in setting mode.
P	Test mode is active (arrow flashing)
Lp	Load profile memory has been activated
StE	Control of energy and demand tariffs through external control input

Assignment of functions to the cursor arrows can be parameterized.

Displaying the meter's tariff and demand reset sources

The tariff source active at any particular time, plus the source for the meter's maximum reset, can be called up into the display via the identifier C.70 as a 2-digit numerical value.

The Identifiers involved here are:

- Indication of the demand reset source (**1st digit**)
 - "0": no maximum reset
 - "1": control input
 - "2": internal LCR
 - "3": internal clock
 - "4": internal LCR / internal clock
 - "5": internal LCR / external control input
 - "6": internal LCR / internal clock / external control input
 - "7": internal clock / external control input

- Indication of tariff source (**2nd digit**)

2 nd digit	Energy tariff	Demand tariff
0	No tariff source	No tariff source
1	Control inputs	Control inputs
2	Internal LCR	Internal LCR
3	Internal clock	Internal clock
4	No tariff source	Internal clock
5	Control inputs	No tariff source
6	Internal LCR	Control inputs
7	Internal clock	Internal LCR
8	No tariff source	Internal LCR
9	Control inputs	Internal clock
A	Internal LCR	No tariff source
B	Internal clock	Control inputs
C	No tariff source	Control inputs
D	Control inputs	Internal LCR
E	Internal LCR	Internal clock
F	Internal clock	No tariff source

6.2 Display Modes

The following principles apply for display control:

Alternate button

- pressing briefly (<2s) switches to the next list value or menu option
- pressing for longer (2s < t < 5s) either activates the menu options currently being displayed or causes preceding values to be skipped
- pressing the alternate button for longer (>5 s) returns you from any display mode back into the scroll mode (rolling display)

Demand Reset button

- pressing it for any length of time in operating display mode always causes a reset
- pressing it for any length of time in setting mode always causes the digit or value being edited to be accepted

Further principles:

- The display control and the edit function for settable values are handled by means of "**single-hand operator control**" in conformity with the stipulations of the VDEW - Specification, i.e. it is never necessary to operate more than one control at any one time.
- Depiction of the different values on the display in the various display modes can be parameterized.
- The default status for the display is the operating display. A change from the operating display to the "Menu [A]-key" (i.e. call or load profile) or to the "Menu [R]-key" (i.e. setting or high-resolution mode) is possible only through the "display test".
- From call, load profile, setting or test mode, you jump back into the operating display through the end-of-list identifier, or automatically if no control is operated within a defined time of 30 minutes, for example, or if the alternate button has been pressed for longer than 5 s.
- The end of a list is designated in the display with the word "End" in the value range.
- Since in setting mode values can also be edited via the data interface, the interface and the operator control functions are mutually (logically) interlocked.

Different operating modes for the display:

- Scroll Mode
- Display test
- Call mode "Menu alternate button"
 - Standard call mode ("**Std-dAtA**", displaying all the list's register contents)
 - Second call mode ("**Abl-dAtA**", displaying all the list's register contents)
 - Load profile call mode "**P.01**", displaying load profile data)
 - Logfile call mode "**P.98**", displaying log file data)
- Call mode "Menu reset button"
 - Setting mode ("**SEt**", for editing settable variables)
 - High-resolution test mode for testing purposes ("**tESt**", test mode)

6.3 Scroll mode

The operating display is the standard display function. The measured values involved are displayed in rolling mode, with the data relevant to billing being displayed for a parameterizable duration (e.g. 10 s). While a measured value is actually being displayed, then it will not be updated in the scroll mode.

6.4 Display test mode

Pressing the alternate button (<5 s) causes the meter to switch over from rolling display to display test mode, in which all segments on the display are activated. The display test mode is retained from approx. 3 seconds after the alternate button is released.

During the display test mode, you can

- * press the alternate button to switch to the "**A-button menu**"
- * press the reset key to switch to the "**R-button menu**"

6.5 A-button menu

The first value displayed in the menu list is the single-call menu option entitled "**Std-dAtA**". Every time you press the alternate button briefly again, more menu options as available will be displayed, e.g. the load profile "**P.01**" or the second alternate list "**AbI-dAtA**". For purposes of menu option selection, the alternate button must be held down for at least 2 s.

If the time limit after the last touch on the button has been reached (this can be parameterized in a range from 1 min to 2 h) or the alternate button has been kept depressed for not less than 5 s, the meter will automatically switch over to the scroll mode.

While a measured value is being displayed in this mode, it will be updated in the display once a second.

6.5.1 Standard mode (Menu Option "**Std-dAtA**")

The first value displayed in the call list is the Identifier and the content of the function error. Every time the alternate button is pressed again, further data will be displayed. In order to call up data more quickly, existing preceding values can be skipped and the value following the preceding values can be displayed. You do this by keeping the alternate button pressed down for longer than 2 s.

If the time limit after the last touch on the button has been reached (this can be parameterized in a range from 1 min to 2 h) or the alternate button has been kept depressed for not less than 5 s, the meter will automatically switch over to the operating display. Extending the time limit gives you an option for testing the meter without any software tools, since the LED will flash either for +P, -P, +P/-P or Q1.. Q4, etc., depending on the measured variable being displayed (active or reactive power consumption).

The final value in the call list is the end-of-list identifier, which is designated in the display's value range by the word "**End**".

6.5.2 Second Standard mode (Menu Option "Abl-dAtA")

Furthermore the meter supports a second standard data list ("Abl-dAtA"). The handling of this list is the same as described in chapter 4.5.1. The main difference between this 2 lists is, that the "Abl-dAtA" list can be set without breaking the certification seal.

6.5.3 Load profile mode (Menu option „P.01“)

6.5.3.1 Date selection for the day block

The first value displayed in the list is the date of the most recent available day block in the load profile. Every time the alternate button is pressed briefly (<2 s) again, the display will show the preceding available day in the load profile.

If the alternate button is pressed for >2 s, then for precise analysis of the day block selected the day profile will be displayed in increments of the demand integration period, provided no events have led to the demand integration period being cancelled or shortened.

If the time limit after the last touch on the button has been reached (this can be parameterized in a range from 1 min to 2 h) or the alternate button has been kept depressed for not less than 5 s, the meter will automatically switch over to the operating display.

The final value in the call list is the end-of-list identifier, which is designated in the display's value range by the word "**End**".

6.5.3.2 Load profile values of the selected day

Display of the day block selected begins by showing the oldest load profile values stored on this day (the value stored at 0.00 h is assigned to the preceding day), beginning with the lowest EDIS Identifier from left to right (time, Channel 1 value, .. Channel n value). Every time the alternate button is pressed briefly (<2 s) again, the next available measured value for the same demand integration period will be displayed. Once all the period's measured values have been displayed, they are followed by the data of the next available demand period.

The last value in the call list is the end-of-list identifier, which is designated in the display's value range by the word "**End**" and which appears after the final load profile value of the day selected. If the alternate button is pressed for >2 s, the meter will switch back to the day block previously selected from the date list.

If the time limit after the last touch on the button has been reached (this can be parameterized in a range from 1 min to 2 h) or the alternate button has been kept depressed for not less than 5 s, the meter will automatically switch over to the operating display.

6.6 R-button menu

The first value displayed from the menu list is the setting mode menu option, called "**SEt**". Every time the alternate button is pressed briefly (<2 s) again, any other menu options available will be displayed, e.g. the high-resolution mode for test purpose, called "**tESt**". To select a menu option, the alternate button must be held down for longer than 2 s. The final value in the call list is the end-of-list identifier, which is designated in the display's value range by the word "**End**".

If the time limit after the last touch on the button has been reached (this can be parameterized in a range from 1 min to 2 h) or the alternate button has been kept depressed for not less than 5 s, the meter will automatically switch over to the operating display.

6.6.1 Setting mode (Menu option „Set“)

In the setting mode, settable parameters are entered using the reset button and/or the alternate button. The values concerned can likewise be altered through the optical or electrical interface. While date and time are being set, the Identifier concerned is shown on the display.

6.6.1.1 Setting date and time with pushbutton control

In order to set the meter's data and time, you have to press the reset button during the display test. The current time will then appear in the display. You press the alternate button to switch to "Set date", and the reset button to enable you to enter the time.

For this purpose, the hours must be entered using the alternate button and confirmed with the reset button. You then enter the minutes and seconds. After you have confirmed your entry for the seconds, the complete time display will flash, and will not be accepted until you have pressed the set button.

After entering the time, you can enter the date into the meter in the same way. For all entries, the meter runs a plausibility check, i.e. only valid values will be accepted.

After data and time have been set, the meter automatically assumes its correct setpoint status, i.e. in the case of a clock timer function the meter will autonomously switch to its ongoing tariff. For reasons of a possible maloperation, the reset disable is activated for 1 - 2 minutes at the end of this setting routine, to prevent a reset being triggered accidentally.

6.6.1.2 Set of energy/demand tariff source by using alternate and demand reset button

In the same way like the setting of time & date the energy and tariff source can be set by using the alternate and demand reset button. The tariff source for energy and demand tariff can be selected separately.

- Internal tariff clock
- Internal ripple receiver
- External control inputs

For single tariff meter configuration the whole menu will not be displayed.

The internal ripple receiver can only be activated if he is enabled through the basic configuration.

6.6.2 High resolution mode for test purposes (Menu option „tEst“)

In the "Test" operating mode, the display will show the same data as in the scroll mode, but rolling, and with the difference that energy registers are displayed in high resolution. Each time the alternate button is pressed, further data will be displayed. If the alternate button is held down for at least 5 seconds, the meter will automatically switch to the operating display.

Test mode is quit via the following events:

- formatted command
- 24h after activation
- [A]-button pressed >5s

6.7 Set of time and date

6.7.1 Set of time and day through communication interface

You can also set the date and time through the interfaces provided in the meter (optical, CLO and RS232), using a password protection feature.

Another safeguard incorporated is that date/time setting is enabled only when the reset button (located underneath the power utility's lead seal) is pressed. This interlock can be parameterized.

While the meter is in setting mode, the **Set** arrow is switched on in the display.

The protocol for setting date and time has been implemented in conformity with VDEW Specification V2.0.

6.7.2 Set of time and date by using DCF77 antenna

The meter date and time can although be set by using the DCF77 antenna input. The decoding of the DCF77 signal, delivered by the active antenna, is realized inside the meter (See chapter 11.3).

6.7.3 Set of time and date by using the alternate and demand reset button

See chapter 6.6.1.1

6.8 Flow chart of different display modes

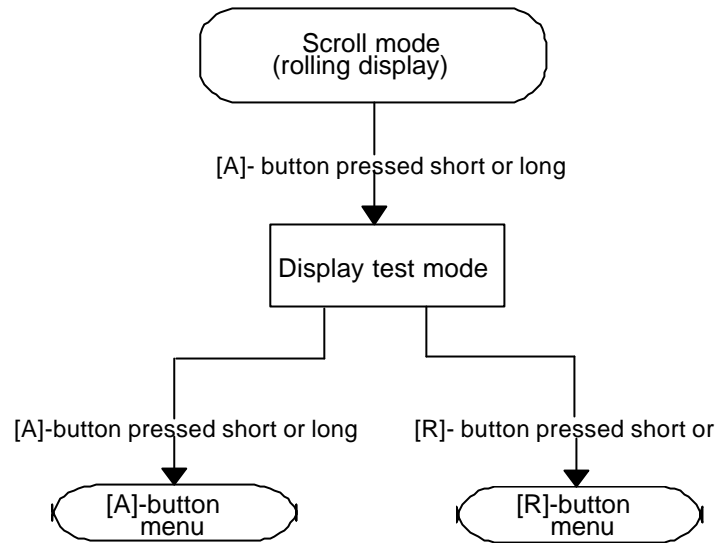

Fig. 3 Changes of different display modes

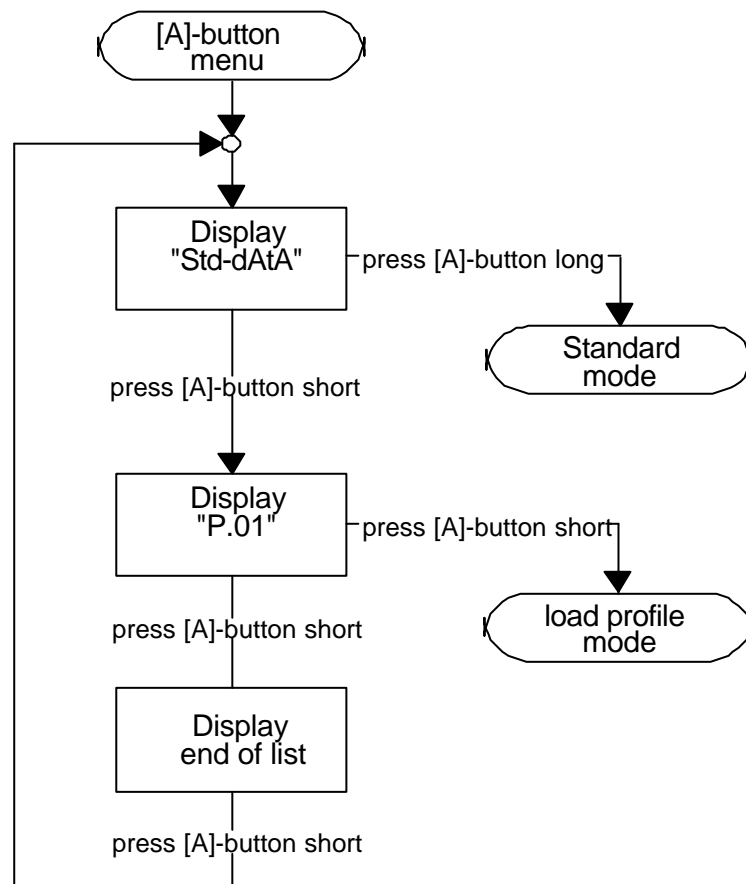

Fig. 4 A-button menu

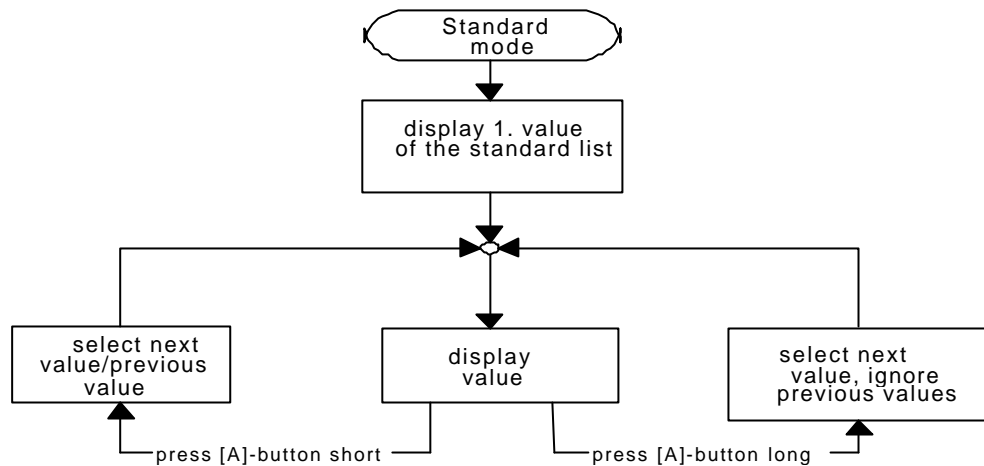

Fig. 5 Single call display

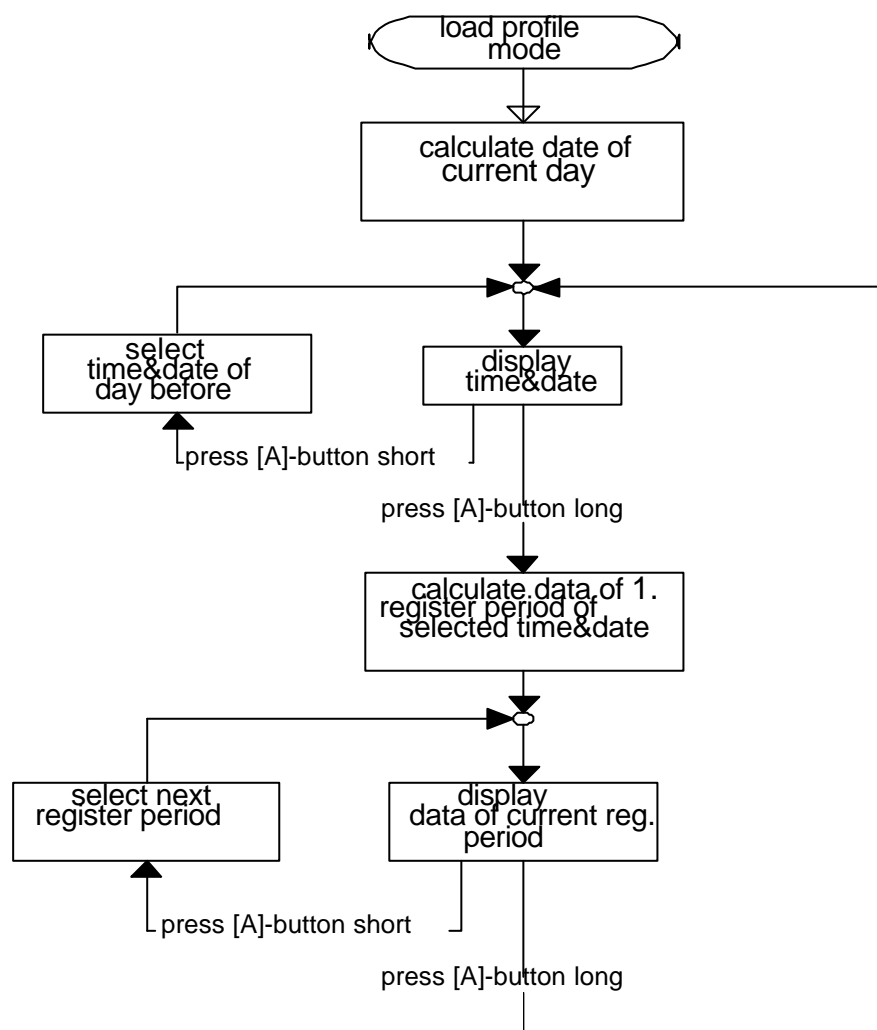

Fig. 6 Load profile display

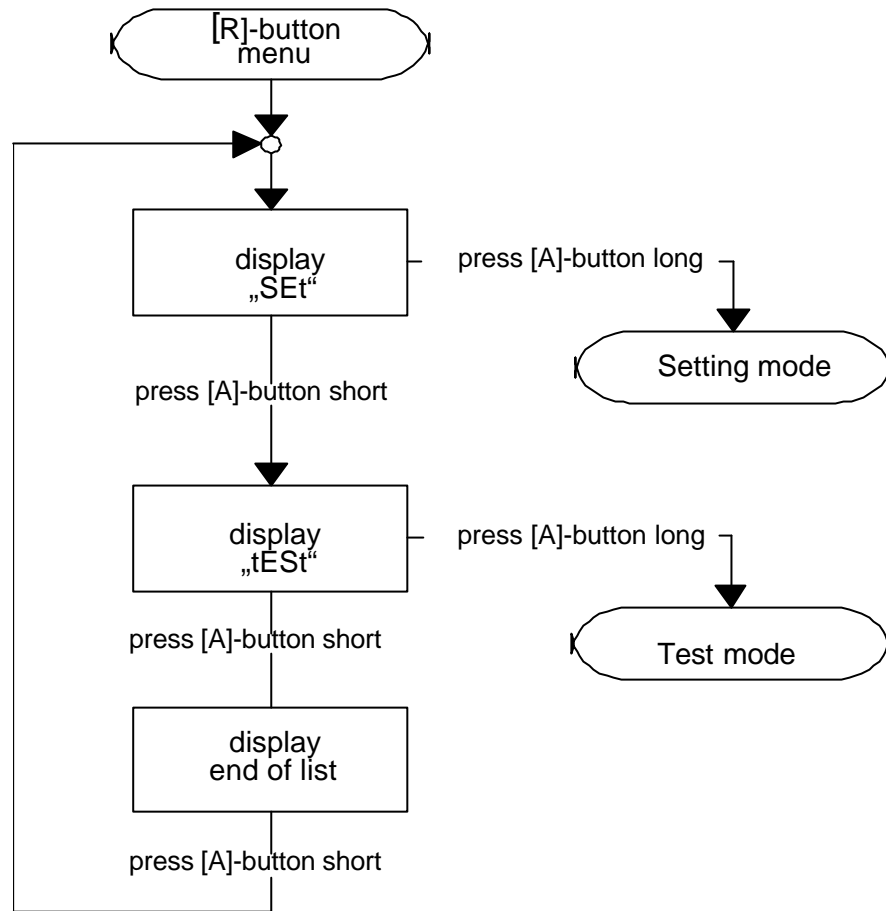

Fig. 7 R-button menu

6.9 Demand reset

The demand reset of all energy/demand register can be executed by:

- the secured and lead-sealable demand reset button
- an external electrical signal (LCR or clock)
- an internal signal from the integrated clock
- a demand reset request through one of the data interfaces

The demand reset of the meter possesses the following characteristics:

- A demand reset by pressing the reset button can be performed in the scroll mode or the alternate mode([A]-mode).
- At every demand reset, a reset disable is activated, i.e. the "RS1" or "RS2" arrow in the display will flash. The demand reset disable time can be parameterized from 1min to 4.5 h.

	Disable times for a new demand reset by triggering a reset through...	1	2	3	4	5
1	... button	t_1	0	0	0	0
2	... interfaces (optical, electrical)	0	t_1	0	0	0
3	... external control	0	0	t_1	t_1	t_1
4	... internal device clock of the internal integration period sensor	0	0	t_1	t_1	t_1

- A demand reset executed through an appropriate control input is operative only if the demand reset disable time is not active.
- The demand reset disable is cancelled by an all-pole power failure.
- If during an activated demand reset disable another reset is executed through the optical or electrical data interface, then on the display all segments will be made to show the letter "E" to indicate a maloperation.
- The demand reset counting mechanism can run either from 0..99 or from 1..12, to correspond to the months of a year. The number of the reset counting mechanism simultaneously serves as an auxiliary Identifier for the preceding values. During the register reading list the symbol "&" or "*" displays whether the demand reset was activated by pressing the push button or an other medium (internal clock, formatted command, control input).

1-1:1.2.1	0.134 kW	
1-1:1.2.1*01	0.230 kW	Demand reset activation by internal clock or external input
1-1:1.2.1&02	0.212 kW	demand reset activation by push button

Remark: By use of the modulo 12 counter, the number of the counter refers to the month

- Resetting via the data interface is safeguarded by a password, and acts on both all maximum tariffs and energy tariffs.
- The performance of a demand reset by the demand reset button of one of the interfaces will be always done directly. Only by using an external demand reset input or the integrated ripple receiver the demand reset can be delayed, if it is configured.
- During the test mode every demand reset will be performed directly.

7 Identifier system

The *alpha* Meter's Identifier system can be parameterized by the user, with a total of 7 Identifier digits provided for the display and the readout over the optical and electrical interfaces. The user has the option for using an own identifier system but to follow the international standardization the OBIS Identifier system (EN 62056-61) is recommended (see appendix, chapter 20).

7.1 Standard data readout list

In the attached table you will find a sample of a data readout list of a meter with active and reactive and demand measurement and 2 tariffs. The standard data readout list contains all billing data.

OBIS-identifier	Format on the display	Length	Designation
F.F	Xxxxxxxx	8	Error condition
0.0.0	XXXXXXXXXX	8	Identification number
0.0.1	XXXXXXXXXX	8	Additional Identification
0.1.0	XX	2	Demand reset counter
0.9.1	hh:mm:ss	8	Actual time
0.9.2	JJ-MM-TT	8	Actual date
1.2.1	XXX.XXX	6	Cumulative demand, tariff 1
1.2.2	XXX.XXX	6	Cumulative demand, tariff 2
1.4.0	XXX X.XXX	3 4	Actual time of the demand period actual demand of the period
1.6.1	X.XXX	4	Demand, tariff 1
1.6.1.VV	X.XXX		Demand, tariff 1, historical value
1.6.2	X.XXX	4	Demand, tariff 2
1.6.2.VV	X.XXX	4	Demand, tariff 2, historical value
1.8.1	XXXXX.XX	7	+A, active energy, tariff 1
1.8.1.VV	XXXXX.XX	7	+A, active energy, tariff 1, historical value
1.8.2	XXXXX.XX	7	+A, active energy, tariff 2
1.8.2.VV	XXXXX.XX	7	+A, active energy, tariff 2, historical value
3.8.1	XXXXX.XX	7	+R, reactive energy, tariff 1
3.8.1.VV	XXXXX.XX	7	+R, reactive energy, tariff 1, historical value
3.8.2	XXXXX.XX	7	+R, reactive energy, tariff 2
3.8.2.VV	XXXXX.XX	7	+R, reactive energy, tariff 2, historical value
C.3	Xxxxxxxx	8	Status of input / outputs
C.4	Xxxxxxxx	8	Status of internal signals

Remark: All parameters of the standard data readout lists can only be changed by breaking the certification seal of the meter:

7.2 Service list - second data readout list

In the attached table you will find a sample of a service data readout list of a meter. All parameters of this list can be changed without breaking the certification seal, only a password is required.

OBIS-identifier	Format on the display	max length	Designation
31.7	XXX.X	6	Current phase L1
51.7	XXX.X	6	Current phase L2
71.7	XXX.X	6	Current phase L3
32.7	XXX.X	6	Voltage phase L1
52.7	XXX.X	6	Voltage phase L2
72.7	XXX.X	6	Voltage phase L3
33.7	X.XX	6	Power factor phase L1
53.7	X.XX	6	Power factor phase L2
73.7	X.XX	6	Power factor phase L3
1.7	XXX.X	6	Active demand, +P, total
21.7	XXX.X	6	Active demand, +P, phase L1
41.7	XXX.X	6	Active demand, +P, phase L2
61.7	XXX.X	6	Active demand, +P, phase L3
C.7.1	XX	2	Number of outages in phase L1
C.7.2	XX	2	Number of outages in phase L2
C.7.1	XX	2	Number of outages in phase 1
C.52	XXXXXX	6	Start date of last 3 ph. power outage
C.53	XXXXXX	6	Start time of last 3 ph. power outage
C.54	XXXXXX	6	End date of last 3 ph. power outage
C.55	XXXXXX	6	End date of last 3 ph. power outage

7.3 OBIS formatted read and write operations

The table below provides information on which single registers and OBIS Identifier can be read or written. The "R5" and "W5" commands defined in conformity with DIN EN 61107 are used for this purpose:

ODIS - identifier	Significance	Commands R5 / R6 / W5	Remarks
P.01	Read/erase load profile	yes / yes / yes	
P.98	Read / erase operating logfile	yes / yes / yes	
0.9.1	Read time	yes / no / no	
0.9.1	Set time	no / no / yes	
0.9.2	Read date	yes / no / no	
0.9.2	Set date	no / no / yes	

Table 1: Register for EDIS-formatted read and write functions

Remark:

In addition, the "R5" command can be used to read out individually all the registers contained in the readout list.

8 Tariff characteristics

8.1 General remarks

The tariff module of the *alpha* meter processes the counting pulses provided by the measuring module, monitors the integrated communication modules, and operates the meter's interfaces. Depending on the meter parameterization involved, all or only some of the functions described below will be supported.

It is possible to use a separate tariff source for the energy and the demand tariffs control.

8.2 Energy tariff control

Overall, the meter provides 8 register sets for acquiring the following variables:

- imported active energy +A
- exported active energy -A
- reactive energies R_1 .. R_4 of the 4 energy quadrants
- combination of reactive energies, e.g. $+R=R_1 + R_2$
- apparent energy

a) Internal clock timer

See Section 8.7.4

b) External control

The meter possesses up to 6 potential-free inputs for tariff control, with the control voltage corresponding to the meter's rated voltages. The "voltage present" assignment corresponds to T1 or T2, or T3 or T4, as required.

8.3 Maximum demand tariff control

4 separate maximum registers are provided for power measurement, with their input variables user-selectable. The total parameters provided for maximum control are as follows:

- duration of the maximum period: 15 min (parameterizable in the range of 1..60 min)
- up to 4 separate maximum registers each with 4 maximum tariffs M1 .. M4 and 4 cumulative counting mechanisms
- input variables for the 4 maximum values are user-selectable, e.g. +P/Q1, +P/+Q/+S
- maximum tariffs and energy tariffs are independent of each other
- temporary maximum measurements
- overlapping maximum measurements
- each maximum value is assigned a time stamp
- saving up to 15 preceding-month values

8.3.1 Active- reactive- and apparent demand measurement

The meter has the possibility to measure the maximum demand of the following 3 quantities simultaneously:

- active demand
- reactive demand
- apparent demand

The calculation of the apparent demand is done at the end of the demand period.

8.3.2 Control options for demand tariff information

There are 2 different options for controlling the various maximum tariffs:

a) Internal clock timer

See Section 8.7.4

c) External control

The meter possesses up to 6 potential-free inputs for maximum control. The control voltage corresponds to the meter's rated voltage. The "voltage present" assignment can be selected between M1 or M2, or M3 or M4.

8.3.3 Synchronization of the demand period

The integration period for the meter's maximum measurement function can be synchronized in a number of different, parameterizable ways:

- Power failure
 - a) Integration period is ended
 - b) Integration period is not ended
- Power recovery
 - a) A new integration period is started, and terminated synchronously with the device time
 - a) Depending on the duration of the interruption, either the integration period ongoing at the time of the power failure will be continued, or a new (and perhaps shortened) integration period will be begun. The end of the integration period is always specified by the IP raster.
- Energy tariff change
 - a) Energy tariff is switched over, and the integration period is affected if energy and power are not being jointly controlled
 - b) The tariff is changed after a time-delay, and synchronized with the integration period raster specified by the device clock, if it has not occurred synchronously
- Demand tariff change
 - a) The power tariff will be changed immediately, the ongoing integration period switched over, and a new integration period started
 - b) The tariff is changed after a time-delay, and synchronized with the integration period raster specified by the device clock, if it has not occurred synchronously
- Demand Reset
 - a) Ongoing integration period is ended, new integration period is started with the beginning of the new billing period
 - b) The reset is accepted as preparation, but not actually executed until the next time the time filed in the device comes round (this does not apply for resets with the reset button or through the optical interface)
- Setting device clock
 - a) Setting the device clock causes the demand integration period to be terminated prematurely. The following integration period is terminated synchronously with the device time, and may be shortened if the resetting has not been synchronized so as to harmonize with the integration period raster.

8.4 Energy and demand tariff sources

The energy and demand tariff can be controlled by separate tariff sources (See table below):

Tariff source	Energy tariff control	Demand tariff control
Internal tariff clock		
External inputs		

8.5 Oversetting of the internal tariff source

If the tariffs will be controlled by the internal tariff source it is possible to disable the internal tariff source and set the energy and demand tariff in a predefined status by using an external control input or a relay of the integrated ripple receiver.

After resetting the control input or the relay of the integrated ripple receiver the tariffs will be controlled by the internal tariff source again.

Control input	internal tariff source	energy/demand tariff
„0“	active	according the internal tariff source
„1“	not active	selectable

8.6 Delta register values

A delta value or counting mechanism increment is the energy value which has accumulated as a preceding value since the last demand reset. In comparison to the register reading, the Delta value represents the energy of the variable measured between two defined points in time. In the *alpha* Meter, Delta values and register readings can be displayed in parallel. When Delta values are displayed and read out, they are identified with their own Identifier, distinguishable from the meter readings.

8.7 Real time clock

8.7.1 General characteristics of the real time clock

The A2500's real-time clock possesses the following characteristics:

- The time basis is derived from the line frequency or (on request) from a quartz with an accuracy of 5ppm (+/- 0.5s per day).
- In the event of interruptions in the mains power supply, the quartz will take over as the clock's time basis
- The energy for the running reserve is supplied by a supercap (10 days backup time).
- After the running reserve has been exhausted, the device clock will start after power up with the time and date information of the last power outage. If a device clock has been integrated, the cursor labeled "Clk" will flash. An associated error identifier can be read out.
- Time and date must be set manually by pressing the display and reset buttons together, through the optical or CLO interface.
- The real-time clock supplies the time stamp for all events inside the meter, such as time stamp for maximum measurement, time stamp for voltage interruptions, etc.
- The real-time clock can be synchronized by using an external DCF77-antenna (chap. 8.3)
- It has been specified that two-digit year figures from 90 up to and including 99 are assigned to the twentieth century. Two-digit year figures in the range from 0 to 89 will be linked to the twenty-first century.

8.7.2 Battery characteristic

To keep the RTC of the meter running the A2500 can optionally be equipped with an exchangeable Lithium-battery or an onboard soldered battery. The used battery is situated below the name plate in the upper right corner of the meter. The features of the battery are:

- Nominal voltage: 3,6V
- Nominal capacity: 0,95Ah
- Temperature range: -55 ... +85°C
- Life time: >10 years (nominal conditions)
- Back up time for RTC: >10 years (nominal conditions)

Remark: by using the battery a parameter in the meter must be activated by using the *alphaSet* tool

8.7.3 Correction the device clock

There are several options for correcting the device clock. "Correcting" in this context means "**synchronization**" of the device clock, i.e. the clock's deviation lies in the range of 1% of the demand period. In this case, a running integration period will not be restarted. If the deviation is greater than this specified value, we speak of "**setting**", i.e. the clock is synchronized and the integration period restarted.

- Correcting the real-time clock using the data interface
- Correcting the real-time clock using the alternate and demand reset buttons
- Correcting the real-time clock using the synchronization input
- Correcting the real-time clock using the DCF77 antenna input

By using the synchronization input to synchronize the device clock, a distinction must be drawn between the following 3 cases:

8.7.3.1 Correction the device clock with „integration period end“

The device clock can be continuously corrected using a control signal at the "External measuring period" input. If the external control signal fails, the device clock will continue to run with its own inherent accuracy. When the "integration period end" signal re-appears, the device clock will immediately be corrected in the sense of "synchronization". If the deviation at this juncture is greater, i.e. the end of the integration period specifiable with the device clock lies outside the time window permissible under "synchronization", referenced to the "integration period end" signal arriving again, then the device clock will be set. The decision as to whether the device clock is to be set forwards or backwards is found by rounding to the next time interval limit.

The time window inside which the device clock is synchronized has been agreed with a time deviation of 1% of the period, with the time involved being the time between the reference edge of the "integration period end" signal and the reference time of the device clock.

8.7.3.2 Correction the device clock on a minute base

In this procedure, the "integration period end" signal supplies a pulse for correction (setting or synchronizing) the device clock once or several times a day. If the signal is not received, the device clock will continue to run with its own inherent accuracy until the signal re-appears. If the second value is in the range between 0 and 29 when the signal for correction arrives, then the device clock's second value will be set to "0", without any change to the higher-order variables (minute, hour, date). If, however, this value is in the range between 30 and 59, then the second value will be set to "0" and the higher-order variables will be set to the next minute on the rounding-up principle.

8.7.3.3 Correction the device clock daily

In this procedure, the "integration period end" signal supplies a pulse for correcting (setting or synchronizing) the device clock only once a day. If the signal is not received, the device lock will continue to run with its own inherent accuracy until the signal reappears. In order to preclude malfunctions, a time window can be set (e.g. 22:55 to 23:05), inside which the device clock will accept the "integration period end" signal at all. In addition, you have to set a time which sets the device clock when the "integration period end" signal is detected (e.g. 23:00).

8.7.4 Internal tariff clock

The internal tariff clock can be used to control tariff switchover functions at specified times of the day. The switching times are here defined by the switching table. For up to 4 different day types (e.g. workday, Saturday, Sunday, Holiday), different switching tables can be specified. In addition, up to 4 seasons can be defined, with an option for having different switching tables in each of the seasons concerned. The maximum possible number of switching tables is thus:

$$4 \text{ day types} * 4 \text{ seasons} = 16 \text{ switching tables}$$

Example of a switching table:

- Switching table applies for Season 1 (1 Jan - 31 March)
- Within Season 1, the switching table applies on workdays only
- Switching times:

06:00	T1,M1 operative
22:00	T2,M2 operative, etc.

For the "Holiday" day type, the meter incorporates a Holiday table, where a year's fixed and movable Holidays can be entered.

The parameters for the integrated clock timer can be read off at the meter's display using a switching number.

Besides tariff control, the integrated lock timer is also used to form the maximum integration period and the time stamps for maximum demand, load profile and logbook (Fig. 8).

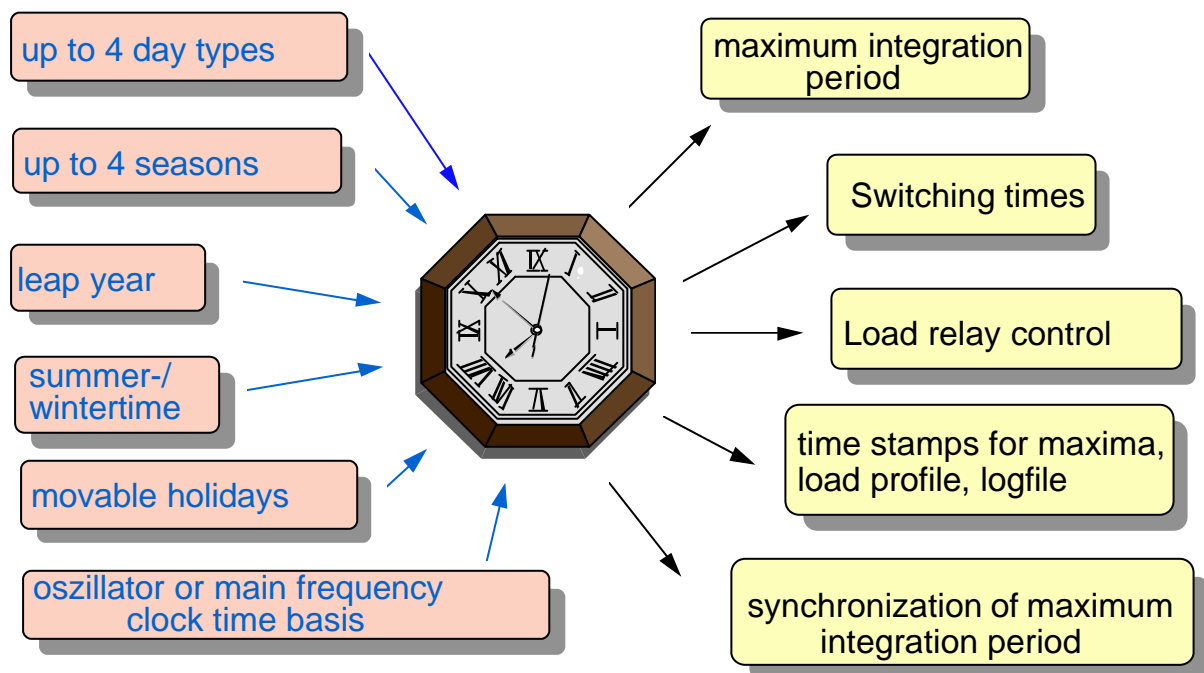

Fig. 8 Functionality of integrated clock

9 Load profile of billing data

By using the internal load profile storage the actual demand or energy over a selectable period (1..60min) can be stored. At the end of the storage capacity the oldest value of the load profile will be overwritten by the actual one.

With the load profile memory approved by the PTB, load profile memory contents are interrogated and output in conformity with DIN EN 61107.

The contents of the output data records are formatted in terms of their data structure in conformity with EN 62056-61 (OBIS).

The load profile memory possesses the following characteristics:

- Number of channels: 1-8
- Measuring quantities: +P, -P, Q1, Q2, Q3, Q4, +Q, -Q, +S, -S
- Memory depth: at least 420 days for 1 channel (15 min period)

remark: the size of the load profile storage decreases with the number of channels

The following types of measuring values can be stored in the load profile storage:

- Demand values per period
- Energy values per period
- Energy Register every period

9.1.1 Features of the load profile storage

- Load profiles are read out using the formatted "R5" command, which causes a load profile formatted with EDIS to be output. The reply generated by the meter here is given as a self-sufficient telegram.
- Recorded profiles can be deleted using the "W5 " command defined to supplement DIN EN 61107
Please note: erasing the load profile memory will automatically erase the logfile erase.
- If the meter does not support the EDIS Identifier requested, it will return this as an echo response. The part contained in the reply telegram between the two brackets (which function as separators) is omitted completely.
- If in conjunction with the load profile readout there is no entry in the inquiry for the EDIS Identifier of a measured value, the meter will respond with all available measured values in its profile.
- If the meter does not incorporate an internal device clock, then the following data will be output instead of the time stamp:
 - for the date of the string: "999999" (OBIS Format: D6)
 - for the time of the string: "999999" (OBIS Format: Z6)
 - for the time stamp of the string "999999999999"
- The telegram formed as the reply corresponds to the form specified in OBIS. It contains in the "Address" field of the first data record the OBIS Identifier of the first load profile excerpt of the reply. This is followed, in accordance with the definition specified in OBIS, by a header-specific number of bracketed additional values, to which are appended the likewise bracketed elements of the load profile excerpt.
- If in the interval specified there is more than one section of the load profile, then a new header will be inserted for each such section. The formation of new profile headers during

load profile transfer is explained with the events and status changes coded in the first 8 bits (Bits 7 to 0) of the profile status word. The time stamp in the header is assigned not to the transactions, but to the formation of the first profile value.

- The overall length of the telegram answered will depend on the size of the interval desired. The time stamps in the reply telegram are of the "ZSTs13" type. Output of the telegram's data always begins with the oldest interrogated value.
- If the order includes a request for a time range for which there are no entries, the meter will respond with "P.01 (ERROR)".
- If the order requests a Identifier which the meter does not support, the meter will merely supply the values for the Identifier it does know.

9.1.2 Depiction of load profile in the data telegram

KZ	(ZSTs13)	(S)	(RP)	(z)	(KZ ₁)(E ₁) .. (KZ _z)(E _z)	(M _{w1})	...	(M _{wz})
<- header of load profile entry					-> <- Meas. value of load profile ->			

- * KZ OBIS-Identifier "P.01"
- * ZSTs13 Time stamp of the oldest measured value
- * S Profile status word

Bit	Significance
b7	Power failure
b6	Power recovery
b5	Change of time/date
b4	Demand reset
b3	Seasonal switchover (summer/winter time)
b2	Measure value disturbed
b1	Running reserve exhausted
b0	Fatal device error

- * RP Demand integration period in minutes
- * z Number of different measured values in one demand integration period
- * KZ_n Identifier of the measured values (without tariff particulars or preceding-value Identifier)
- * E₁ Units of measured values
- * M_{wn} Measured values

remark: Bit b4 can be configured with as follows:

- Bit b4 set after demand reset
- Bit b4 set after 1-phase or 2-phase power outage

9.1.3 Load profile readout by using R5 / R6 - command

The orders listed below can be sent to the meter:

Order	EDIS-Identifer Template: GG.AA	Parameters required (the brackets are separators in conformity with DIN EN 61107)	Remarks
Readout of load profile	P.01	Readout of the load profile completely available in the meter (;)	1) If you want all the measured values of the load profile to be read, then "KZn" Identifier are omitted
	P.01	Complete readout of the measured values with the EDIS Identifier "KZ(1..n)" (;)(KZ1) .. (KZn)	2) The semicolon must also be transferred, as a special separator
	P.01	Readout of all measured values on an interval: (ZSTs11 ; ZSTs11)	3) The time stamp before the semicolon displays the beginning of the interval for readout
	P.01	Readout of the measured values with the EDIS Identifier "KZ(1..n)" in an interval: (ZSTs11 ; ZSTs11)(KZ1) .. (KZn)	4) The time stamp behind the semicolon displays the end of the interval for readout
	P.01	Readout of all measured values from the beginning of load profile recording in the meter up to an end time (;ZSTs11)	5) Both time stamps are located inside the interval limit
	P.01	Readout of the measured values with the EDIS Identifier "KZ(1..n)" from the beginning of load profile recording in the meter up to an end time (;ZSTs11)(KZ1) .. (KZn)	6) If a time stamp is omitted, the beginning or the end of the load profile record in the meter will be used as the interval limit
	P.01	Readout of all measured values from a starting point to the end of the record in the meter: (ZSTs11;)	7) The sequence of the values output by the meter need not correspond to the sequence in the request telegram
	P.01	Readout of the measured values with the EDIS-Identifer "KZ(1..n)" from a starting time to the end of the record in the meter: (ZSTs11;)(KZ1) .. (KZn)	

The use of the R6-command for reading load profile data is optimized for remote metering. The advantage of that command is:

- Segmentation of data block
- Data security of every segment
- Automatic repeat of disturbed segments

=> the R6 command is optimized for remote metering

10 Setting parameters

The setting parameters are safeguarded by a password for transmission through the optical or electrical interface. In addition, the meter can be set so as to ensure that before transmission begins the reset button has to be pressed.

The A2500 possesses the following parameters which can be set via the interfaces without breaking any certification seal of the meter:

- Date and time (Formatted command)
- Juncture for summer/winter changeover (Formatted command)
- Maximum reset (Formatted command)
- Duration of reset disable
- Inputs for integrated clock timer
 - switching times
 - switching tables
 - summer/winter changeover
- Activation of tariff switchover by
 - internal clock timer
 - external tariff terminals
- Activation of maximum demand reset by
 - internal clock timer
 - external tariff terminals
- Display control
 - scroll time for the operating display
 - maximum dwell duration of a value on the display
 - all parameters of second display data list "AbI-dAtA"
- Reference time for external time correction via the integrated ripple control receiver or control input with the associated time window
- Power utility password
- Property Number
- Meter address and meter identification in conformity with IEC 1107
- Communication baud rate
 - for optical interface
 - for electrical interfaces

- Activation of setting mode
 - through password protection
 - through password protection and button control
- Thresholds of overload control
- Passwords
 - for setting mode via data interface
 - for EDIS write commands ("W5" commands)
- Time base of the meter
 - line frequency
 - internal oscillator
- instantaneous measurement
 - enable / disable parameters
 - assignment to service list (second data readout list)
- profile of instantaneous measurement
 - enable / disable parameters
 - readout options
 - defining of profile channels

11 Inputs / Outputs

11.1 Interfaces

Different interfaces like optical, CL0- RS232- or RS485 interface are available for reading or configuring the meter. Using one of these interfaces the meter can be readout by an handheld unit or PC in combination with an optical probe or by connection the meter to a modem for AMR purposes.

The data protocol is implemented according mode A,B,C or Mode D of DIN EN 61107. The communication baud rates are configurable.

11.1.1 Optical interface

Electrical characteristics: as per EN 61107
Protocol: as per EN 61107
Baud rate: max. 9600 baud

11.1.2 CL0-interface

Electrical characteristics: DIN 66348
Protocol: as per EN 61107
Baud rate: max. 19200 baud

11.1.3 RS232-C interface

Electrical characteristics: terminals brought out: RxD, TxD, Gnd
Protocol: as per EN 61107
Baud rate: max. 19200 baud

11.1.4 RS485-inteface

Electrical characteristics: terminals brought out: +RxD, +TxD, (-RxD, -TxD)
Protocol: as per EN 61107, Status January 1994
Baud rate: max. 19200 baud

By using the RS485 interface up to 32 meters can be connected with a line length of 1000m. The used protocol corresponds to EN 61107. In that case the IEC meter address should be used for reading the meters.

2-Draht Bus (max. 32 Teilnehmer)

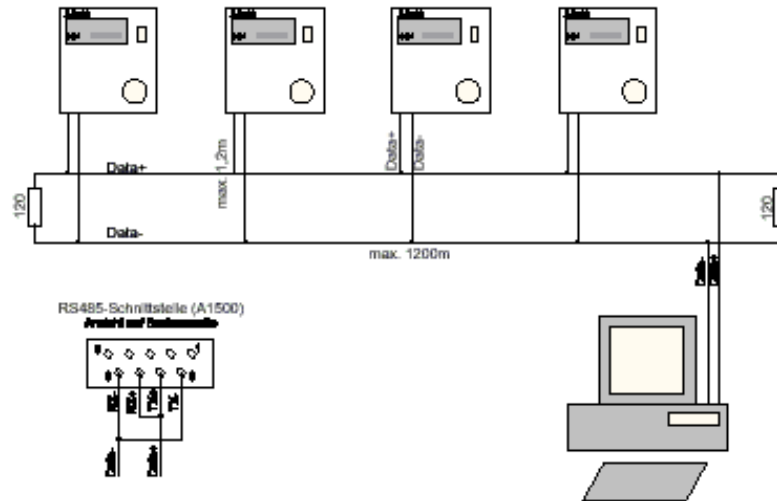

4-Draht Bus (max. 32 Teilnehmer)

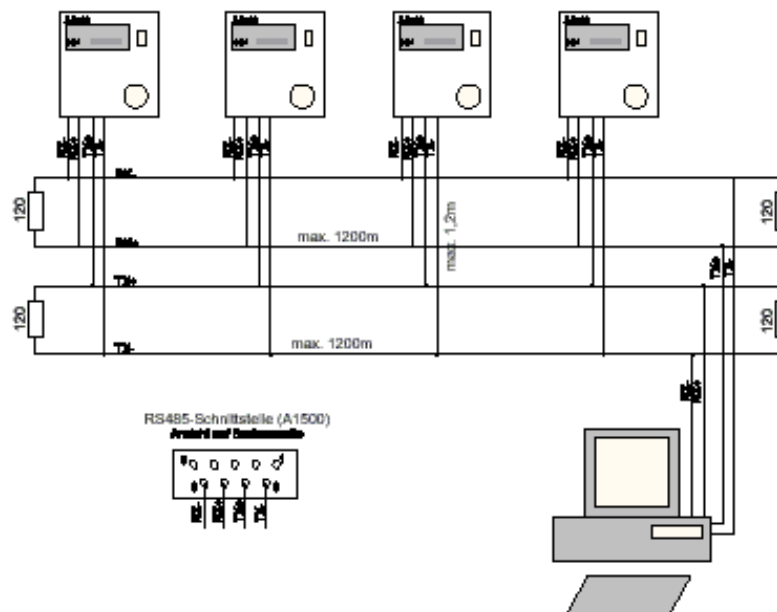

11.1.5 Use „without baud rate changeover“

To provide for the use of simple telephone modems, the user has the option for specifying the baud rate of the opening sequence (under DIN EN 61107 this is 300 baud) by parameterizing it to a different value in the range of 300 .. 19200 baud. The opening sequence is performed with the parameterized baud rate, but baud rate switchover between the two communication partners (meter and HHU or telephone modem) is not executed.

11.1.6 Separate data readout lists

The meter data can be read out both via the optical interface and via the electrical interface. Note that there is an option for defining different readout lists for the optical and the electrical interfaces.

11.2 Control inputs

The meter provides up to 4 control inputs. The input voltage at the inputs corresponds to the meter's wide range supply voltage. Assignment of the control inputs to the corresponding functions is user-parameterizable.

- Energy tariff T1-T4 or demand M1-M4
- Maximum demand, temporary
- Maximum demand reset
- Integration period synchronization

Electrical characteristics:

- OFF at $\leq 47V$, ON at $\geq 51V$
- Internal resistance $>120k\ \Omega$
- ON delay, typically 8 ms

11.3 Synchronization input by using the DCF77- antenna

By using a S0-input of the meter it is possible to connect an external DCF77-antenna. The decoding of the time & date signal is realized inside the meter. With this solution the customer owns a cost effective solution to synchronize the internal clock of the meter, which gets more and more important in the deregulated market by using the internal load profile storage.

The features of the DCF77antenna input are:

- The takeover of the DCF77 time & date is caused only by detecting two correct succeeding telegrams
- The takeover of the time & date signal is caused after every power up and 5 minute after every hour
- By detecting a incorrect telegram an warning will be displayed until the next correct decoding.

11.4 Mechanical control output

An optional board can be used to provide users with one potential-free control outputs (1A relay). Here, too, assignment to the various functions involved is user-selectable.

- Maximum demand M1-M4, energy tariff T1-T4
- Maximum demand, temporary

- Maximum demand reset
- Integration period output
- Energy direction display
- System error display
- Load control through integrated clock or ripple control receiver

Electrical characteristics:

- Close/open contact (parameter)
- Max. switching current 1A AC/DC
- Max. switching voltage 250V AC/DC

11.5 Electronic outputs

The standard version provides the user with 6 electronic outputs. The outputs have the following electrical characteristics:

- Version with SO outputs as per DIN 43864, Sept. 1986
- Connection to meter's power supply possible
- Max. switching current 100 mA AC/DC
- Max. switching voltage: 360 V peak value
- Resistance in ON state: $\leq 25 \text{ Ohm}$

The electronic outputs can be used as control outputs (see chapter 11.5.1) or as pulse outputs (see chapter 11.5.2).

11.5.1 Electronic control outputs

The assignment of the control outputs is user-parameterizable:

- Energy tariff T1-T4 information
- Maximum demand tariff M1-M2 information
- Maximum demand reset
- Alarm indication
- End of interval
- Overload conditions
- Power outage (single or 3-phase)

11.5.2 Electronic pulse outputs

The assignment of the pulse outputs to the individual measured variables is user-parameterizable:

- Active energy +A (import)
- Active energy -A (export)
- Reactive energy R1
- Reactive energy R2
- Reactive energy R3
- Reactive energy R4
- Combinations of measured variables, such as
+A/-A
+R=R1+R2

11.6 Overload Control

With the A2500 it is possible to use an control output for load control opportunities. After exceeding a predefined threshold an output contact can be closed (opened). The user can define 2 different thresholds for up to 2 control outputs.

- The format of the selectable overload threshold and the demand are the same.
- At the begin of the period the output contact will be opened (closed)
- The output contact will be closed (opened) under the following conditions:

$$P_{15} > P_{\text{threshold}}$$

with P_{15} : actual 15min demand ($P_{15} = P * t / t_p$)
 $P_{\text{threshold}}$: overload threshold
 t_p : demand period (15min)
 t : actual time of the 15min demand period

- example
 nominal voltage: 3x230/400V
 current: 6A
 Overload threshold: 0.5kW

$$t = (P_{\text{threshold}} / P) * 15\text{min} = 0.5 / (3 * 230 * 6) * 15\text{min} = 01:49 \text{ (mm:ss)}$$

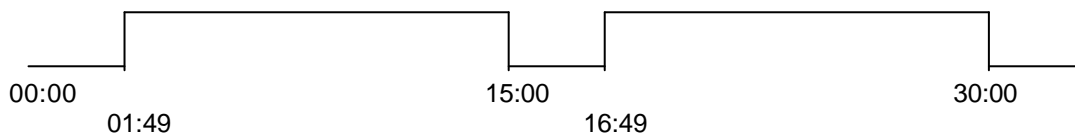

11.7 Electronic pulse inputs

In the standard configuration of the A2500 the user can have 1 pulse input (by not using the DCF77 decoding input). Optionally 2 more pulse inputs can be used. All pulse inputs are realized according the S0 standard.

Every pulse input can get a separate pulse constant. The summation of the pulses in combination with the pulse constant will be counted in a separate register which can be readout by the standard register data list. The pulse input 1 can be used as:

- DCF77- antenna input
- S1-Pulse input
- Synchronization input (attention! No connection to 230V, only 27V DC possible).

11.8 Auxiliary power supply

With the A2500 an auxiliary wide range power supply with the following characteristic can be used as an option:

- 48V ... 230V AC/DC +/-15%

By connecting the meter to an auxiliary power supply the total consumption of the meter will be delivered automatically by the auxiliary power supply. After the auxiliary power supply fails the consumption of the meter has to be delivered by the voltage transformers.

12 Security functions

12.1 Error messages

The A2500 electronic meter regularly executes self-test routines running in the background. These are used to test all important parts for proper functioning.

If there is a malfunction or an operator error, the error messages and/or diagnostic alarms on the display will output a detailed error Identifier, which can be evaluated via the optical or electrical interfaces. It can contain one or more error messages.

12.2 Error messages according VDEW-specification

There is also an option for displaying the error message in conformity with the EDIS Identifier Number system and the VDEW Specification (Identifier "F.F"). Note that the VDEW Specification subdivides errors into 4 groups. The significance of the individual bits in each group can be selected on a manufacturer-specific basis. In the *alpha* Meter, the following specifications for fatal errors apply, beginning from the left:

12.2.1 Certification relevant alarms

Error identification with EDIS Identifier F.F

If an error of this kind occurs, the meter's certification will be cancelled, and the display will be frozen ("F.F * * * * *"). An error message of this kind cannot be acknowledged in the meter's setting mode. The error identifier can also be read out through the electrical interface.

0	0	0	0	0	0	0	0		
						x	x:	gen.:	other fatal errors
				x	x:			gen.:	fatal checksum errors
				0	1:			checksum error of	parametrisation class
				0	2:			checksum error of	billing data
				0	4:			checksum of	ELSTER parametrisation class
		x	x:			allg.:	fatal error during read or write operation		
		0	1:			I ² C-Bus-error			
		0	2:			communication error with large load profile storage			
x	x:								

12.2.2 Non Certification relevant alarms

Error identification with EDIS Identifier F.F.1

If an alarm of this kind occurs, the display will be frozen ("F.F.1 * * * * *"). An alarm of this kind can be acknowledged in the meter's setting mode, and likewise read out through the electrical interface.

0 0 0 0 0 0 0 0	
1:	communication error with integrated ripple receiver
x x:	reserved
1:	non fatal checksum error of setting class
1:	terminal cover removal detection
x	reserved
1:	battery change necessary
1:	lost of time and date

12.2.3 Diagnostic messages

Error identification with EDIS Identifier F.F.2

If a diagnostic message of this type occurs, it is output on the display in a rolling depiction with "F.F.2 * * * * *". A diagnostic message of this kind can likewise be read out through the electrical interface.

0 0 0 0 0 0 0 0	
1	failure of one or more phase voltages
1	One time communication error between meter uP and meter chip
1	reverse run detection
1	One time communication error between meter uP and ripple receiver
1	load profile stopped
1	Overload 1 exceed
2	Overload 2 exceed
1	no correct DCF77-signal receipt
x:	reserved

12.3 Log file

12.3.1 Characteristic of the log file

By using the logfile of the meter the following events can be recorded with the actual time & date stamp:

- Power outage (3-phase and/or per phase)
- Power up (3-phase and/or per phase)
- Change of time & date
- Malfunction of the meter
- Demand reset
- Reset of load profile/logfile
- Energy or demand tariff change
- Loss of time & date
- Change of meter configuration

12.3.2 Certified log file

The log file of the meter can be used as a „certified log file“. It is not possible to delete the log file without breaking the certification seal. Therefore it is allowed to change the meter LED and pulse output constants under the following conditions:

- The indication of the pulse constant have to be displayed on the LCD, not on the name plate
- The change of the pulse constant is done by formatted command
- Every change of the pulse constants will be registered in the log file with
Time & date stamp: identifier, previous constant, new constant
- The logfile can only be erased by breaking the certification seal
- The load profile storage has the same size as the load profile storage

12.3.3 Log file format

The meter's operating logbook entries can be read out in accordance with the procedure selected for outputting the load profile:

- The operating logfile is treated like a load profile. The Identifier "P.98" designates the operating logbook of the VDEW Specification meter
- The operating logfile is read out using the "R5" formatted commands, which are specified as follows to supplement DIN EN 61107:
The "R5" command causes a load profile formatted with EDIS to be output. The answer generated by the meter in response is given as a self-sufficient telegram.
- Erasure of the operating logfile is performed using the "W5" command defined to supplement DIN EN 61107.
Erasing the logfile automatically causes the load profile memory to be erased
- The telegram supplied as a reply corresponds to the form of a logfile profile as specified in EDIS.
- If a time range is requested in the order, but there are no entries for it, the meter will respond with "P.98 (ERROR)".
- The status word describes the event or the status change which has led to the event in the logbook. In the status bit, however, it is perfectly possible for more than one status bit to be set to "1". Which event entails which element information is defined below:

12.3.4 Depiction of a logfile in the data telegram

KZ	(ZSTs13)	(S)	()	(z)	(KZ ₁) .. (KZ _z)	(Element ₁)	...	(Element _z)
Header of the log file entry					->	content of the log file - >		

- KZ OBIS-Identifier "P.98"
- ZSTs13 Time stamp of logbook entry
- S Profile status word, whose change occurred at the time ZSTs13
- () Corresponds to "RP" with load profiles, not required here
- z Number of elements in a logfile entry; if no element is required, the bracket content is set to "0"
- KZ₁ Identifier of the element "(Element₁)" in the logfile entry

Bit	Identifier	Unit	Format	Meaning	Remark
b15	---	---	---	---	not used
b14	---	---	---	Erase load profile	The time stamp entry contains date & time of the LP memory erasure
b13	---	---	---	Erase logbook	The time stamp entry contains date and time of the logbook erasure
b12	---	---	---	---	Not used
b11	---	---	---	---	Not used
b10	---	---	---	End of impermiss. operating condition	The time stamp entry contains date and time of the event
b9	---	---	---	Impermissible operating condition detected	The time stamp entry contains Date and time of the status concerned
b8	---	---	---	Set variables	The time stamp entry contains the date and time when the variables were set
b7	---	---	---	3-phase power failure	The time stamp entry contains date and time of the event
b6	---	---	---	Power up after 3-phase failure	The time stamp contains date and time of the event
b5	0.9.1 0.9.2	none none	ZS6, ZS7 DS6, DS7	Device clock has been set New time New date	1) The time stamp of the logbook contains date/time of the clock before setting 2) The logbook's element designated by "Date" contains the date after the clock has been set 3) The logbook element designated by "Time " contains the time after the clock has been set
b4	---	---	---	Reset	The time stamp of the logbook entry contains date and time of the event
b3	0.9.1 0.9.2	none none	ZS6, ZS7 DS6, DS7	Summer/winter time changeover New time New date	1) The time stamp of the logbook contains date/time of the clock before setting 2) The logbook's element designated by "Date" contains the date after the clock has been set 3) The logbook element designated by "Time " contains the time after the clock has been set
b2	---	---	---	Measured value disturbed	The time stamp entry contains date and time of the status change
b1	---	---	---	Running reserve exhausted	The time stamp entry contains date and time of the status change
b0	F.F	none	S8	Fatal device error	1) The time stamp contains date and time of detection of the fatal error status 2) The element content contains the error identifier as a 4-byte word.

12.3.5 Readout modes of the log file by using R5 / R6 - commands

The orders listed below can be sent to the meter:

Order	OBIS Identifier Template: GG.AA	Parameters required (the brackets are separators in conformity with DIN EN 61107)	Remarks
Readout of operating logbook	P.98	Readout of the operating logbook completely available in the meter (;)	1) The semicolon must Also be transferred, as a special separator
	P.98	Readout of an interval: (ZSTs11 ; ZSTs11)	2) The time stamp before the semicolon designates the begin of the readout interval
	P.98	Readout from the beginning of the logbook record in the meter up to an end time (;ZSTs11)	3) The time stamp behind the semicolon designates the end of the interval for readout
	P.98	Readout from a starting time up to the end of the record in the meter: (ZSTs11;)	4) Both time stamps are inside the interval limits 4) If a time stamp is omitted, then the beginning or the end of the logbook record in the meter will be used as the interval limit

12.4 Events of of standard register data list

In addition to the logfile, the following events, errors or operating malfunctions can be outputted in the A2500 in the normal readout mode, using the appropriate OBDIS Identifier:

- Number of total duration of all power failures
- Number of power failures per phase
- Beginning and end of the last interruption in power supply
- Number of communication processes
- Number of maximum resets
- Date and time of the last maximum reset
- Number of mains power failures
- Date of last parameterization
- Error messages
- Status information (wrong rotation field, power outage, etc., see chapter 9.7)

12.5 Data integrity

In designing the A1500, special attention has been paid to measuring stability and the integrity of the billing data acquired. The extensive integrity concept is based on several different components. Crucial parts of the hardware are in redundant design. Billing data are, for example, filed in an EEPROM and also held in a buffered RAM. This means the integrity of these data can be cross-checked. In the software, checksums are regularly formed for the crucial billing and parameterization data. Any malfunction is immediately indicated on the display with an informative error message. There is also an option for closing a forwarding contact, if a malfunction occurs. Data are saved automatically in the EEPROM:

- during an all-pole power failure
- after a tariff or maximum switchover
- or at the latest every 24 h

12.6 Password protection

The *alpha* Meter possesses a password protection feature on 2 different levels, enabling all the parameters accessible for the customer to be protected.

- Customer Password 1
 - Protection for EDIS-formatted write commands ("W5" commands)
 - Protection for all the meter's setting parameters
- ELSTER password
 - Protection for specific areas of the meter not accessible to the customer

12.7 Display of meter status information's

Detailed status information for the meter regarding the state of its inputs and outputs can be read out using appropriate status words, and shown on the display.

- **Status of the inputs/outputs (Status Word 1)**

Interpretation of the status word with the OBIS-Identifier C.3:

0	0	0	0	0	0	0	0		
							x x:	gen.:	status of the control inputs
							8	Terminal 16	is switched on (Input 3)
							4	Terminal 17	is switched on (Input 4)
							2	Terminal 18	is switched on (Input 5)
							1	Terminal 19	is switched on (Input 6)
							8	Terminal 13 controls T1/2	and is switched on (Input 1)
							4	Terminal 33 controls T3/4	and is switched on (Input 2)
							2	Terminal 14 controls M1/2	and is switched on (Input 1)
							1	Terminal 34 controls M3/4	and is switched on (Input 2)
							x x:	gen.:	status of the relay outputs
							8	Relay Output 1	is switched on
							4	Relay Output 2	is switched on
x	x	x	x					Reserved	or not used

- **Status of internal control signals (Status Word 2)**

Interpretation of the status word with EDIS Identifier C.4:

0	0	0	0	0	0	0	0		
							1	Maximum tariff	M1
							2	Maximum tariff	M2
							4	Maximum tariff	M3
							8	Maximum tariff	M4
							1	Energy tariff	T1
							2	Energy tariff	T2
							4	Energy tariff	T3
							8	Energy tariff	T4
							x x x	Reserved	or not used
							8	Directional signal,	active +
							4	Directional signal,	reactive +
x	x							Reserved	or not used

- **Status of internal operating states (Status Word 3)**

Interpretation of the status word with EDIS Identifier C.5:

0	0	0	0	0	0	0	0		
								x	reserved
								8	Voltage L1
								4	Voltage L2
								2	Voltage L3
								1	Correct rotating field
								x	Reversal disable, active (Reverse warning)
								8	Start-up, active
								4	Start-up, reactive
								8	Parameterization mode
								4	Setting mode
								2	Tariff source clock
								1:	Tariff source ripple control receiver
								x	Reserved or not used
								8	Reset disable, manual
								4	Reset disable, opt. Interface
								2	Reset disable, electrical Interface

12.8 Meter reprogramming security

The A2500 meter can be configured by using one of its interfaces (electrical or optical). The setting parameters are secured by a meter password (see chapter 10).

Billing parameters are additionally secured by a push button, which is located below a certification label. The handling to enable/disable the reprogramming of the meter is described below:

- opening the screw below the certification label (see fig 9) and press the parametrization button.
- If the meter is in the parametrization mode all cursors on the LCD are flashing
- After power outage or sending a formatted command by optical port to the meter the meter parametrization will be disabled and only setting parameters can be changed.

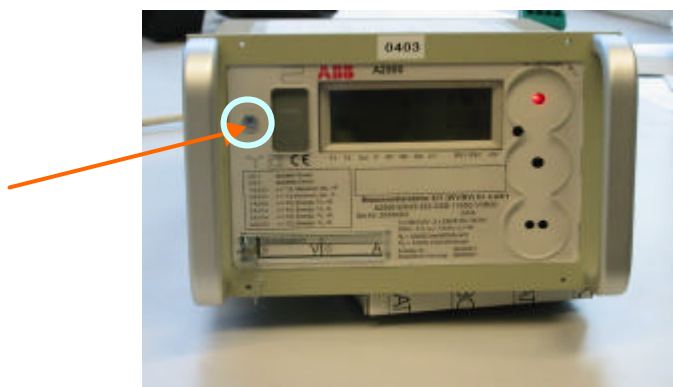

Fig 9: Parametrization button of the A2500

13 Instrumentation measurement

13.1 Instantaneous network parameters

The A2500 meter supports the measurement of the following instantaneous parameters like:

- voltage and current per phase
- Phase angle of current and voltage per phase (referenced to voltage in phase 1)
- Power factor per phase
- active-, reactive- and apparent power per phase
- active-, reactive- and apparent power (total)
- frequency
- 3 selectable harmonics in current and voltage per phase
- total harmonic distortion (THD) in current and voltage per phase

All parameters can be displayed on the LCD or readout by the optical or electrical interface. The activation / deactivation of the measurement can be done without breaking the certification seal.

All instantaneous parameter can be assigned to the standard data readout list or in a separate service list.

The calculation of the network parameters is realized with an accuracy of 0,5% or 1% for the harmonic parameters.

Remark:

- all parameters like phase angle or harmonic calculation are referenced to phase L1
- the following restrictions have to be considered for a 3-wire meter, 2 system meter
 - all calculations are referenced to phase L2
 - all parameters of phase 2 are equal 0
- The updating of the calculation and measuring of the instantaneous data will be done with the following time period
 - Voltage, current, active-, reactive- and apparent power, frequency, power factor, phase angle of current and voltage
8 seconds for all values
 - 3 selectable harmonics in current and voltage per phase
24 seconds for all values
 - Total harmonic distortion (THD) in current and voltage per phase
44 seconds for all values

The total updating time will be about 76 seconds if all instrumentation data are enabled.

13.2 Profile of instrumentation parameters

The load profiling of the network parameters supports the following characteristic:

- use of EN61107 protocol, identical to the readout of the load profile of the billing data
- readout by optical and electrical interface
- Separate load profile interval (1 .. 60min)
- All parameters can be changed without breaking the certification seal
- up to 8 load profile channels
- recording of the following parameters
 - voltage and current per phase
 - Phase angle of current and voltage per phase
 - Power factor per phase
 - active-, reactive- and apparent power per phase
 - active-, reactive- and apparent power (total)
 - frequency
 - 3 selectable harmonics in current and voltage per phase
 - total harmonic distortion (THD) in current and voltage per phase
- recording type per channel
 - average value per interval
 - Minimum value per interval
 - Maximum value per interval
- Data storage depends on the size of the load profile of the billing data

The status bits of the network parameter profile are designed as :

MG: Measurement disturbed

The bit is set at the end of the interval, if after an initialisation or after a power up not all values are calculated.

UV: Change of time & date

With every time&date change the actual interval will be aborted

SA: Power outage

With every power outage the actual interval will be aborted

SW: Power up

After every power up the bit will be set at the end of the interval

The calculation of the network parameters is realized with an accuracy of 0,5% or 1% for the harmonic parameters.

14 Calibration and test

14.1 Calibration

The *alpha* meter A1500 has been adjusted in the factory, with the calibration constants matched to the software concerned. Subsequent calibration by the customer is not required.

14.2 Certification of the meter

Detailed information regarding the meter certification are described in the document „Regeln für die eichtechnische Prüfung des elektronischen alpha Zählers AEM500/A1500“, 1KGL 921530 V004.

14.3 Manufacturer specific test mode

By sending a formatted command through the optical interface, the meter can be put into a special test mode, for reducing the test duration's involved. In this test mode, the following parameters can be selected:

- Automatic increase in the decimal places for energy values to 3, 4 or 5
- Increase in the LED's flashing frequency (Imp/kWh)
- Increase the flashing frequency (Imp/kWh) of the pulse outputs
- Assignment of measured variables (+P, -P, Q1 .. Q4) to the LED
- Selection of desired energy (T1-T4) or demand tariff (M1-M4)

If you switch over to call mode during the test mode, the Identifier selected and the corresponding measured value will remain on the display until a new call is made or the power supply is interrupted. The measured-value display is continually updated.

The test mode can be quit via the following events:

- Formatted command
- 24 hours after activation
- pressing the [A]-button >5s

14.4 Simplified test mode

For a simple function test routine not requiring any special software tools, you can use the following function: if you select a power or energy value in the display, the LED will flash either in accordance with (+P/-P) or in accordance with the reactive power (Q1 .. Q4). This makes it relatively easy to detect which value is being measured. The maximum retention time of the display value can be set by the customer.

If you press the parameterization key before this test, then the display values selected will be retained in the display.

14.5 Simple creep and anti-creep test

The shortened creep and anti-creep test can be shown on the LC display or the shared LED.

- **Display**

Arrow in display "ON": meter starts measuring

Arrow in display "OFF": no energy is being measured. This applies for all 4 possible energy types (+P, -P, +Q, -Q)

- **LED**

The "Standstill" function and "energy-proportional pulse output" are indicated for each energy type by a shared LED. "Standstill" is signaled by a steady-light at the LED. Energy-proportional pulses occur as optical "momentary pulses", with a duration in the 80ms range.

14.6 Manual test mode

The test mode is called up using the meter's reset button (see Section 4.7.2). In this mode, all energy registers are "high-resolution". The resolution of the first digit of the energy register viewed from the right corresponds at least to the resolution of the optical test output.

14.7 Checksum display

By configuration it is possible to display a checksum over all setting- and parametrization classes of the meter. With that 8 digit number is very easy for the customer to proof, if the meters have an identical parameterization.

15 User program

15.1 Reading and configuration tool *alphaset*

The *alpha* Meter A2500 can be read out, set and parameterized via the optical, CLO or RS232 interface, in accordance with the EN 61107 protocol.

For this purpose, you need the *alphaSET* readout and setting tool, which can be used to alter and read out the meter's register contents, load profile and logfile data and all setting parameters. The program is a 32-Bit application and runs under Windows 95/98, Windows 2000, Windows XP and Windows NT.

AlphaSET supports the following functionality:

Readout parameters

- standard data list
- Service list (second data readout list)
- Log file
- Load profile of billing data
- Profile of instrumentation parameters
- Complete meter configuration

Change of meter parameters

- Identification and passwords
- Switch time clock parameters
- Demand reset parameters
- Baud rates
- Pulse constants
- Load profile parameters of billing data
- Instrumentation parameters
- Parameters of instrumentation profile

Formatted commands

- Set time and date
- Set pulse constant
- Reset all counters
- Reset profile of instrumentation parameters
- Reset load profile of billing data
- Reset register data

All parameters can be readout or changed remotely by using transparent GSM or PSTN modems

16 Enclosure

The housing of the A2500 is designed for rack mounted usage. The connections for current voltage and additional input/outputs are situated on the back of the enclosure. The special Essailec connectors allow the user to withdraw the meter without disconnection the voltage and current cables.



Fig. 10 Front and back side of the *alpha* A2500

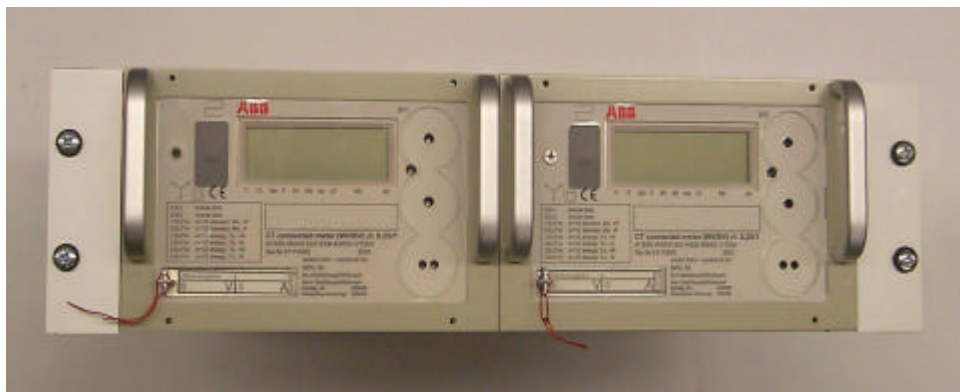

Fig. 11 A2500 installed in a 19" rack

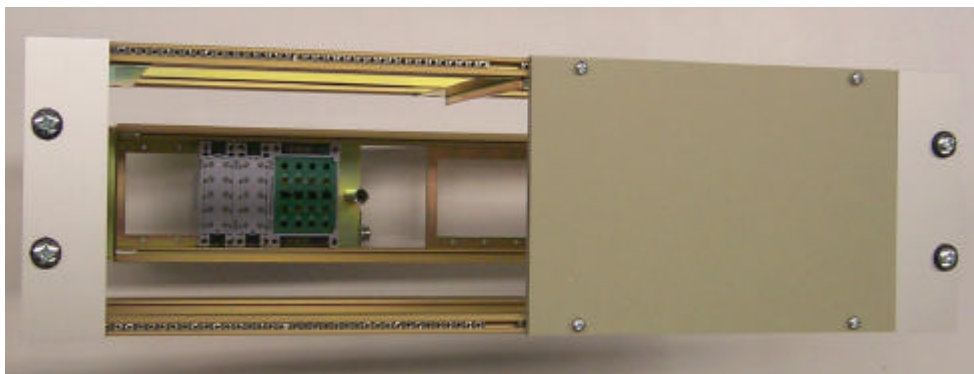

Fig. 12 backside of the 19" rack

16.1 Outside dimensions

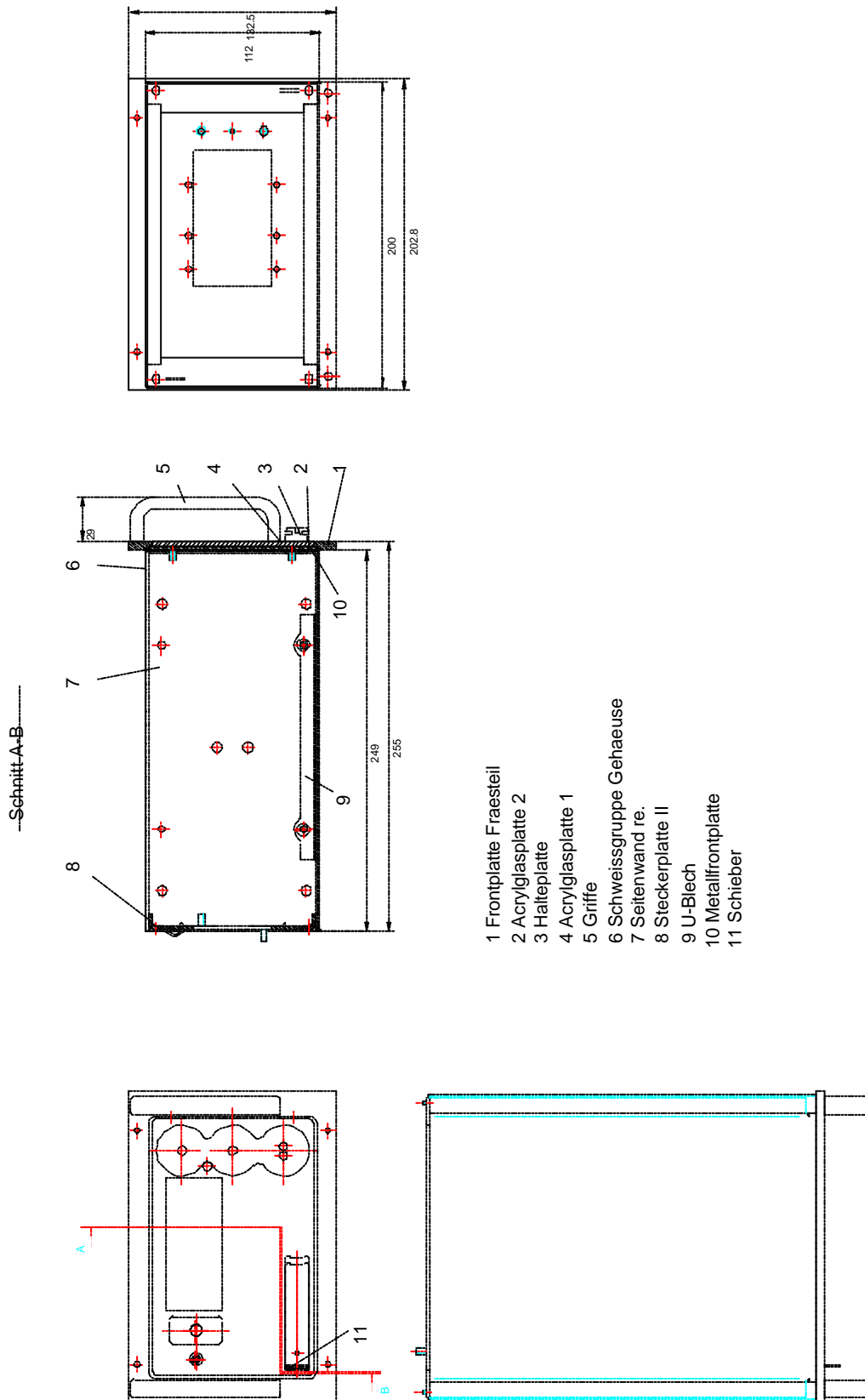

Fig. 13 outside dimensions of the A2500

16.2 Example of connection diagram

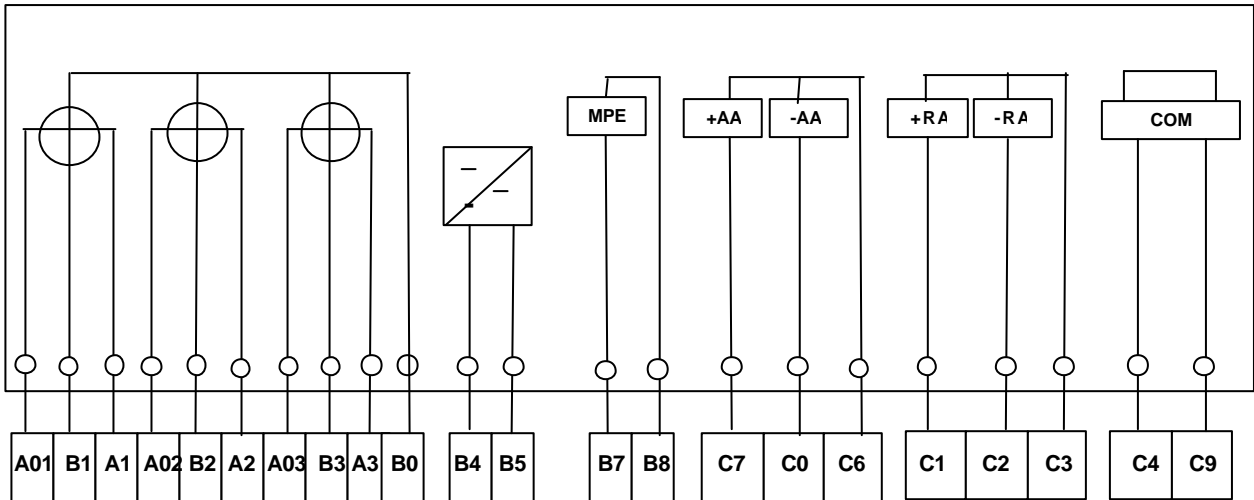

Fig. 14: Connection diagram

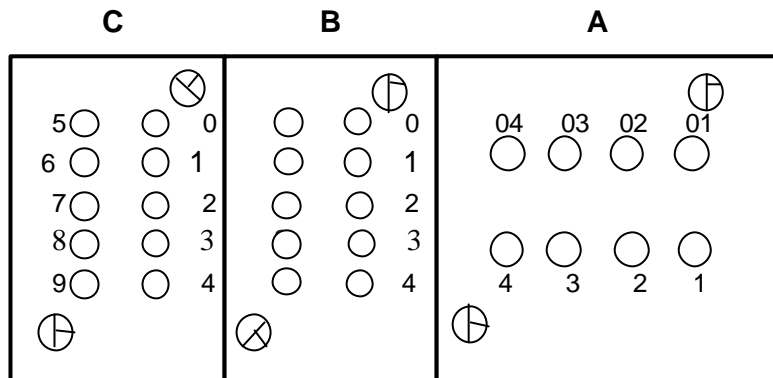

Fig. 15 Essalec connectors

The A2500 standard configuration is with Essalec connectors of block A, B, C. Optionally 2 more blocks (D, E) will be supported.

17 Installation and start-up

17.1 General function monitoring

As soon as the meter has been connected to the power supply, a corresponding indicator in the display will show that the phase voltages L1 to L3 are present.

If the meter has started up, this will be indicated directly by an arrow in the display, and by the energy pulse LED, which will flash in accordance with the preset pulse constant (Fig.15).

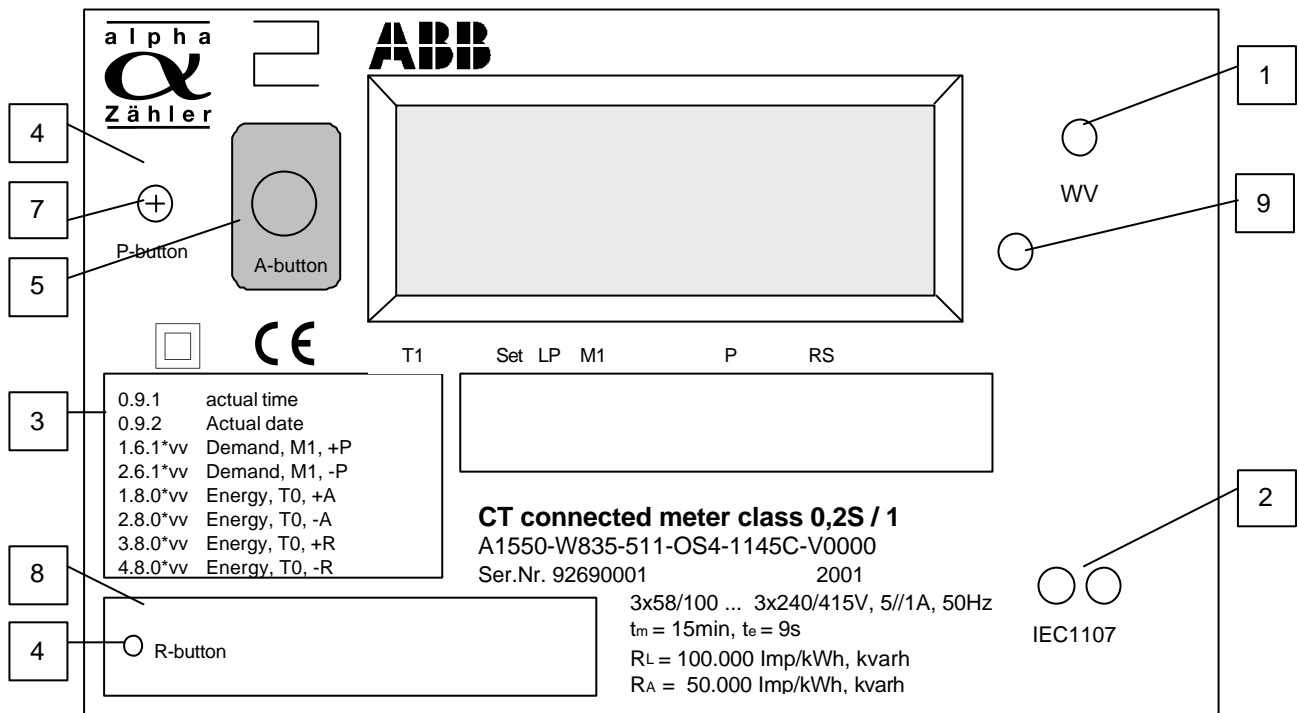

Fig 16: Front view of the meter

On the front panel the following features are displayed:

- 1 LED for energy pulses
- 2 optical interface acc. EN61107
- 3 name plate data
- 4 approval label
- 5 alternate button
- 6 demand reset button
- 7 parameterization button (below the approval label)
- 8 CT/VT ratio label
- 9 Optical display button

17.2 Checking the display

After the meter has been properly connected, its function can be tested as follows:

- Scroll mode** As long as the alternate button is not pressed, the scroll mode will appear. Depending on the version involved, this may consist of one value or of several values, shown in a rolling display mode.
- Display check** When the alternate button is pressed, the first thing to appear is the display check.
All segments of the display must be present. Pressing the alternate button will switch the display to its next value.
- Error message** If the display check is followed by an error message, it can be interpreted as explained in Section 9.
- Fast run-through** If the alternate button is repeatedly pressed at intervals of $2s < t < 5s$, all the main values provided will appear.
- Phase failure** Display elements L1, L2, L3 are used to indicate which phases of the meter are energized.
- Rotating-field detection** If the meter's rotating field has been inversely connected, the phase failure detection symbols will flash.
- Anti creep check** If the meter is in idling mode, the energy pulse diode will be continuously lit up. The relevant arrows (P,Q) on the display are also switched off.

17.3 Installation comment

17.3.1 Fuse protection

Attention !

In the application of meters in the low voltage level the voltage path is direct connected to the phases. Thereby the only security against a short circuit are the primary fuses of some 100A. In that case the whole current is running inside the meter or the connection between phase - phase or phase – neutral, which can cause a lightning or a damage against persons or buildings.

The recommendation for CT connected meters in the low voltage level is the usage of fuses in the voltage path with a maximum of 10A (See fig. 17).

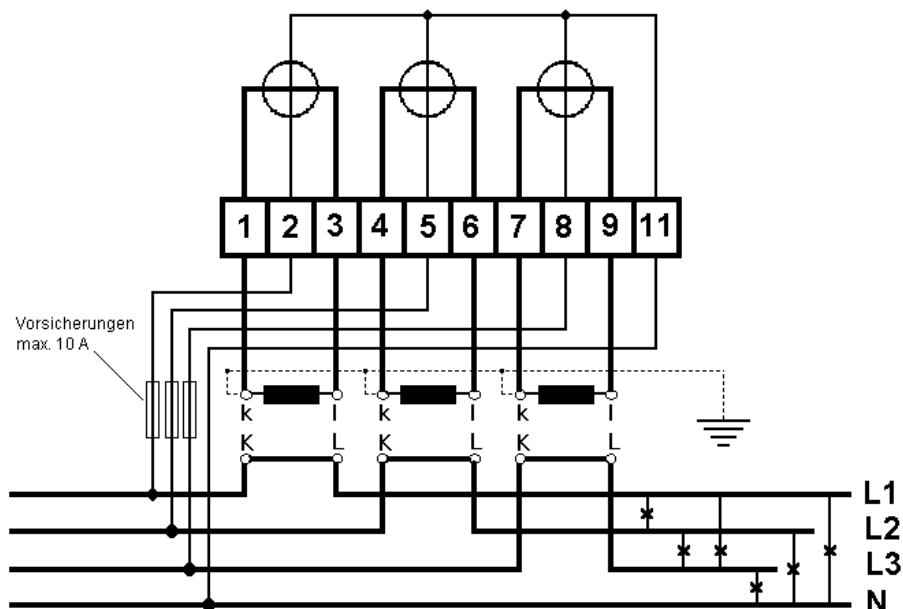

Fig.17 Connection of a CT meter in the low voltage level

17.3.2 Auxiliary power supply connection

By using an auxiliary power supply it is recommended to use a 1A inert fuse to protect the circuit against a short circuit.

18 Type key

		A2500-									
CT connection		W									
3x58/100V .. 3x240/415V		0									
3x230/400V		1									
3x200V (3-wire)		2									
3x58/100V		3									
3x63/110V		4									
3x100V (3-wire)		5									
3x110V (3-wire)		6									
1x100V .. 1 x230V (16,66Hz)		8									
1x100V .. 1 x230V (50Hz)		A									
3x100V ... 3x240V (3-wire)		C									
5 (6) A			2								
1 (2) A			3								
5 // 1 A			4								
5 (15) A			A								
class 0,2S				3							
class 0,5S				5							
class 1				1							
quantity +P	(1.0)				1						
quantity +P,-P	(1.1)				2						
quantity +P,+Q	(2.0)				3						
quantity +P,Q ₁ ,Q ₄	(2.1)				4						
quantity +P,-P,+Q,-Q	(3.0)				5						
quantity +P,-P,Q ₂ ,Q ₃	(3.1)				6						
quantity +P,-P,Q ₁ ..Q ₄	(4.0)				7						
quantity +P,Q ₁					8						
quantity +P,+Q,-Q					9						
quantity +P,-P,+Q,-Q,Q ₁ ,Q ₃					A						
quantity +P,+Q,Q ₄					F						
1 energy tariff						1					
2 energy tariffs						2					
3 energy tariffs						3					
4 energy tariffs						4					
1 demand tariff							1				
2 demand tariffs							2				
3 demand tariffs							3				
4 demand tariffs							4				
0 no demand tariff							0				

19 Name plate

The *alpha* Meter's rating plate contains the following mandatory information:

- Property Number
- Serial Number
- Manufacturer
- Model designation
- Year of manufacture
- Conformity symbol
- Rated voltage
- Rated/Limit current intensity ratio
- Rated frequency
- Accuracy Class
- Output and test pulse constants
- Meter and consumption type
- Symbol for degree of protection
- identifier system



Fig. 18 Example of the A2500 nameplate

20 Technical data of the A2500

Nominal voltage	4-wire, 3 systems 3-wire, 2 systems 2-wire, 1 system	3x58/100V .. 3x240/415V, (+/- 20% Un) 3x100V .. 3x240V, (+/- 20% Un) 1x100V ... 1x240V, (+/- 20% Un)
Nominal frequency		50/60Hz, 16.66Hz +/- 5%
Rated/limit current	Continuous current Short duration	5//1, 1(2)A or 5(6)A other ranges on request 300A für 0,5s
Starting current		<1mA
accuracy		class 1 / 0,5S / 0,2S
Power supply	Nominal voltage Wide range power supply	3x58/100V .. 3x240/415 (+/-20%Un) Still operates even with the failure of 2 phases, or one phase and the neutral
4 control inputs	Control voltage Switching thresholds Isolation	Max. 276V AC „OFF“ at <47V, „ON“ at >51V 6kV, 1,2/50us between input and other circuits
6 electronic outputs - pulse outputs or - control outputs	DC or AC voltages voltage range max. current	5V .. 265V <=100mA
3 pulse inputs	Pulse input / Synchronization input / connection for DCF77 antenna available	Acc. S0-Standard DIN 43864
1 mech. relay output	max. switching power max. voltage / current	1325VA, 10 ⁷ operations 265V DC/AC, 1A DC/AC
Internal tariff source	4 tariffs, 4 seasons weekday dependent tariff accuracy	> 10 days > 10 years < 5ppm (<0,5s per day)
RTC running reserve time	Supercap Battery	> 10 days > 10 years
Temperature conditions	Operating temperature Storage temperature Humidity Temperature coefficient	-30°C ... +60°C -40°C ... +80°C 0 .. 100% re. Humidity, non condensing 0,01% per °C (PF=1), <0,02% (PF=0,5)
interfaces	Optical interface CLO or RS232 or RS485	As per DIN EN 61107 max. 19200 Baud
Auxiliary power supply	Wide range power supply	48V–230V , (+/- 15 Un AC or DC)
EMC compatibility	Surge withstand (1,2/50us) Dielectric test	6kV, R _{source} = 2 Ohm 12kV, R _{source} = 40 Ohm *) 4kV, 1 min, 50Hz
Power consumption	Voltage path Current path Auxiliary power supply	<0,8 W, <1,2 VA per phase <0,01W, <0,01VA per phase <2,3W, <5,2VA
Connections		Essaillec connectors withdrawable under power
Housing		19 inch rack mounted metal box
weight		4kg

21 Appendix

21.1 Parameter of the display and data readout list

The following parameters (identifier + value) can be displayed or readout by the optical or electrical interface.

OBIS-identifier					description	
M-K	GG	AA	T	vv		
					Identification	
1-1:	0	0	0		Utility identification #1 (ASCII)	
1-1:	0	0	1		Utility identification #2 (ASCII)	
1-1:	0	0	2		Utility identification #3 (ASCII)	
1-1:	0	0	3		Utility identification #4 (ASCII)	
1-1:	0	0	4		Utility identification #5 (ASCII)	
1-1:	0	0	5		Utility identification #6 (ASCII)	
1-1:	C	1	0		Firmware checksum	
1-1:	0	2	1		Parameter checksum	
1-1:	0	2	2		Tariff program number	
1-1:	0	2	0		Firmware checksum	
1-1:	C	65			Checksum of configuration parameter	
					Time / date	
1-1:	0	9	1		Actual time	
1-1:	0	9	2		Actual date	
1-1:	0	51			Current season	
1-1:	0	9	5		Current day of the week	
1-1:	C	63			Remaining time in interval	
					Pulse constant / transformer ratio	
1-1:	0	3	0		Pulse constant R_I , active energy	
1-1:	0	3	1		Pulse constant R_I , reactive energy	
1-1:	0	3	3		Pulse constant R_A , active energy	
1-1:	0	3	4		Pulse constant R_A , reactive energy	
1-1:	0	4	2		Current transformer ratio	
1-1:	0	4	3		Voltage transformer ratio	
					Demand reset	
1-1:	0	1	0		Demand reset count	
1-1:	C	70			Reset / Tariff source for energy and demand	
1-1:	0	1	2	xx	Date of demand reset	
1-1:	0	1	3	xx	Time of demand reset	
1-1:	0	9	0		Number of days since last demand reset	
1-1:	C	61			Date of last demand reset	
1-1:	C	63			Resting time of actual demand interval	

					Demand measuring	
1-1:	0	8	0		Actual demand interval	
1-1:	1	4	0		+P, actual maximum demand M0	
1-1:	1	5	0		+P, demand of last interval M0	
1-1:	1	6	1	xx	+P, demand with time/date stamp, M 1	
1-1:	1	2	1	xx	+P, cumulative demand, M1	
1-1:	1	6	1	xx	+P, demand with time/date stamp, M 2	
1-1:	1	2	1	xx	+P, cumulative demand, M2	
1-1:	1	6	1	xx	+P, demand with time/date stamp, M 3	
1-1:	1	2	1	xx	+P, cumulative demand, M3	
1-1:	1	6	1	xx	+P, demand with time/date stamp, M 4	
1-1:	1	2	1	xx	+P, cumulative demand, M4	
1-1:	2	4	0		-P, actual maximum demand M0	
1-1:	2	5	0		-P, demand of last interval M0	
1-1:	2	6	1	xx	-P, demand with time/date stamp, M 1	
1-1:	2	2	1	xx	-P, cumulative demand, M1	
1-1:	2	6	1	xx	-P, demand with time/date stamp, M 2	
1-1:	2	2	1	xx	-P, cumulative demand, M2	
1-1:	2	6	1	xx	-P, demand with time/date stamp, M 3	
1-1:	2	2	1	xx	-P, cumulative demand, M3	
1-1:	2	6	1	xx	-P, demand with time/date stamp, M 4	
1-1:	2	2	1	xx	-P, cumulative demand, M4	
1-1:	3	4	0		+Q, actual maximum demand M0	
1-1:	3	5	0		+Q, demand of last interval M0	
1-1:	3	6	1	xx	+Q, demand with time/date stamp, M 1	
1-1:	3	2	1	xx	+Q, cumulative demand, M1	
1-1:	3	6	1	xx	+Q, demand with time/date stamp, M 2	
1-1:	3	2	1	xx	+Q, cumulative demand, M2	
1-1:	3	6	1	xx	+Q, demand with time/date stamp, M 3	
1-1:	3	2	1	xx	+Q, cumulative demand, M3	
1-1:	3	6	1	xx	+Q, demand with time/date stamp, M 4	
1-1:	3	2	1	xx	+Q, cumulative demand, M4	
1-1:	4	4	0		-Q, actual maximum demand M0	
1-1:	4	5	0		-Q, demand of last interval M0	
1-1:	4	6	1	xx	-Q, demand with time/date stamp, M 1	
1-1:	4	2	1	xx	-Q, cumulative demand, M1	
1-1:	4	6	1	xx	-Q, demand with time/date stamp, M 2	
1-1:	4	2	1	xx	-Q, cumulative demand, M2	
1-1:	4	6	1	xx	-Q, demand with time/date stamp, M 3	
1-1:	4	2	1	xx	-Q, cumulative demand, M3	
1-1:	4	6	1	xx	-Q, demand with time/date stamp, M 4	
1-1:	4	2	1	xx	-Q, cumulative demand, M4	
1-1:	0	5	1	1	Overload threshold 1	
1-1:	0	5	1	2	Overload threshold 2	
					Energy measurement	
1-1:	1	8	0	xx	+A, active energy total, T0	
1-1:	1	8	1	xx	+A, active energy, T1	
1-1:	1	8	2	xx	+A, active energy, T2	
1-1:	1	8	3	xx	+A, active energy, T3	
1-1:	1	8	4	xx	+A, active energy, T4	
1-1:	2	8	0	xx	-A, active energy total, T0	
1-1:	2	8	1	xx	-A, active energy, T1	
1-1:	2	8	2	xx	-A, active energy, T2	
1-1:	2	8	3	xx	-A, active energy, T3	

1-1:	2	8	4	xx	-A, active energy, T4	
1-1:	3	8	0	xx	+R, reactive energy total, T0	
1-1:	3	8	1	xx	+R, reactive energy, T1	
1-1:	3	8	2	xx	+R, reactive energy, T1	
1-1:	3	8	3	xx	+R, reactive energy, T3	
1-1:	3	8	4	xx	+R, reactive energy, T4	
1-1:	4	8	0	xx	-R, reactive energy total, T0	
1-1:	4	8	1	xx	-R, reactive energy, T1	
1-1:	4	8	2	xx	-R, reactive energy, T2	
1-1:	4	8	3	xx	-R, reactive energy, T3	
1-1:	4	8	4	xx	-R, reactive energy, T4	
1-1:	5	8	0	xx	R1, reactive energy total, T0	
1-1:	5	8	1	xx	R1, reactive energy, T1	
1-1:	5	8	2	xx	R1, reactive energy, T2	
1-1:	5	8	3	xx	R1, reactive energy, T3	
1-1:	5	8	4	xx	R1, reactive energy, T4	
1-1:	6	8	0	xx	R2, reactive energy total, T0	
1-1:	6	8	1	xx	R2, reactive energy, T1	
1-1:	6	8	2	xx	R2, reactive energy, T2	
1-1:	6	8	3	xx	R2, reactive energy, T3	
1-1:	6	8	4	xx	R2, reactive energy, T4	
1-1:	7	8	0	xx	R3, reactive energy total, T0	
1-1:	7	8	1	xx	R3, reactive energy, T1	
1-1:	7	8	2	xx	R3, reactive energy, T2	
1-1:	7	8	3	xx	R3, reactive energy, T3	
1-1:	7	8	4	xx	R3, reactive energy, T4	
1-1:	8	8	0	xx	R4, reactive energy total, T0	
1-1:	8	8	1	xx	R4, reactive energy, T1	
1-1:	8	8	2	xx	R4, reactive energy, T2	
1-1:	8	8	3	xx	R4, reactive energy, T3	
1-1:	8	8	4	xx	R4, reactive energy, T4	
1-1:	1	9	0	xx	+A, active energy since last demand reset, T0	
1-1:	1	9	1	xx	+A, active energy since last demand reset, T1	
1-1:	1	9	2	xx	+A, active energy since last demand reset, T2	
1-1:	1	9	3	xx	+A, active energy since last demand reset, T3	
1-1:	1	9	4	xx	+A, active energy since last demand reset, T4	
1-1:	2	9	0	xx	-A, active energy since last demand reset, T0	
1-1:	2	9	1	xx	-A, active energy since last demand reset, T1	
1-1:	2	9	2	xx	-A, active energy since last demand reset, T2	
1-1:	2	9	3	xx	-A, active energy since last demand reset, T3	
1-1:	2	9	4	xx	-A, active energy since last demand reset, T4	
1-1:	3	9	0	xx	+R, reactive energy since last demand reset, T0	
1-1:	3	9	1	xx	+R, reactive energy since last demand reset, T1	
1-1:	3	9	2	xx	+R, reactive energy since last demand reset, T2	
1-1:	3	9	3	xx	+R, reactive energy since last demand reset, T3	
1-1:	3	9	4	xx	+R, reactive energy since last demand reset, T4	
1-1:	4	9	0	xx	-R, reactive energy since last demand reset, T0	
1-1:	4	9	1	xx	-R, reactive energy since last demand reset, T1	
1-1:	4	9	2	xx	-R, reactive energy since last demand reset, T2	
1-1:	4	9	3	xx	-R, reactive energy since last demand reset, T3	
1-1:	4	9	4	xx	-R, reactive energy since last demand reset, T4	
1-1:	5	9	0	xx	R1, reactive energy since last demand reset, T0	
1-1:	5	9	1	xx	R1, reactive energy since last demand reset, T1	
1-1:	5	9	2	xx	R1, reactive energy since last demand reset, T2	

1-1:	5	9	3	xx	R1, reactive energy since last demand reset, T3	
1-1:	5	9	4	xx	R1, reactive energy since last demand reset, T4	
1-1:	6	9	0	xx	R2, reactive energy since last demand reset, T0	
1-1:	6	9	1	xx	R2, reactive energy since last demand reset, T1	
1-1:	6	9	2	xx	R2, reactive energy since last demand reset, T2	
1-1:	6	9	3	xx	R2, reactive energy since last demand reset, T3	
1-1:	6	9	4	xx	R2, reactive energy since last demand reset, T4	
1-1:	7	9	0	xx	R3, reactive energy since last demand reset, T0	
1-1:	7	9	1	xx	R3, reactive energy since last demand reset, T1	
1-1:	7	9	2	xx	R3, reactive energy since last demand reset, T2	
1-1:	7	9	3	xx	R3, reactive energy since last demand reset, T3	
1-1:	7	9	4	xx	R3, reactive energy since last demand reset, T4	
1-1:	8	9	0	xx	R4, reactive energy since last demand reset, T0	
1-1:	8	9	1	xx	R4, reactive energy since last demand reset, T1	
1-1:	8	9	2	xx	R4, reactive energy since last demand reset, T2	
1-1:	8	9	3	xx	R4, reactive energy since last demand reset, T3	
1-1:	8	9	4	xx	R4, reactive energy since last demand reset, T4	
					Pulse inputs	
x-2:	y	8	0		Energy T0, pulse input 1 x: medium (electricity, gas or water) y: energy type (active, reactive)	
x-3:	y	8	0		Energy T0, pulse input 2 x: medium (electricity, gas or water) y: energy type (active, reactive)	
x-4:	y	8	0		Energy T0, pulse input 3 x: medium (electricity, gas or water) y: energy type (active, reactive)	
x-2:	y	9	0		Energy T0 since last demand reset, pulse input 1 x: medium (electricity, gas or water) y: energy type (active, reactive)	
X3:	y	9	0		Energy T0 since last demand reset, pulse input 2 x: medium (electricity, gas or water) y: energy type (active, reactive)	
x-4:	y	9	0		Energy T0 since last demand reset, pulse input 3 x: medium (electricity, gas or water) y: energy type (active, reactive)	
x-2:	0	7	y		Pulse constant R _L , Input 1 , active energy x: medium (electricity, gas or water) y: energy type (active, reactive)	
x-3:	0	7	y		Pulse constant R _L , Input 2 , active energy x: medium (electricity, gas or water) y: energy type (active, reactive)	
x-4:	0	7	y		Pulse constant R _L , Input 3 , active energy x: medium (electricity, gas or water) y: energy type (active, reactive)	
					Errors and warnings	
1-1:	F	F			Fatal errors	
1-1:	F	F	1		Non fatal errors	
1-1:	F	F	2		Warnings	
1-1:	C	7	0		Number of 3-phase power outages	
1-1:	C	7	1		Number of outages in phase in L1	
1-1:	C	7	2		Number of outages in phase in L2	
1-1:	C	7	3		Number of outages in phase in L3	
1-1:	C	52			Start date of last 3-ph. Outage	

1-1:	C	53			Start time of last 3-ph. Outage	
1-1:	C	54			End date of last 3-ph. Outage	
1-1:	C	55			End time of last 3-ph. Outage	
1-1:	C	56			Total duration of all 3 phase power outages	
					Status information	
1-1:	C	3			Status if input/outputs	
1-1:	C	4			Status of internal control inputs	
1-1:	C	5			Status of operational states	
1-1:	C	66			Status of internal ripple receiver relays	
1-1:	C	57			Number of communication processes	
1-1:	C	60			Date of last communication	
1-1:	C	2	0		Number of parameterization / Password uses	
1-1:	C	2	1		Date of last parameterization	
1-1:	C	6	0		Battery hour counter	
1-1:	C	71			Counter for terminal cover removals	
					Instantaneous values	
1-1:	31	7	0		Current phase L1	
1-1:	51	7	0		Current phase L2	
1-1:	71	7	0		Current phase L3	
1-1:	32	7	0		voltage phase L1	
1-1:	52	7	0		voltage phase L2	
1-1:	72	7	0		voltage phase L3	
1-1:	81	7	00		Phase angle of voltage phase L1	
1-1:	81	7	10		Phase angle of voltage phase L2	
1-1:	81	7	20		Phase angle of voltage phase L3	
1-1:	81	7	40		Phase angle of current phase L1	
1-1:	81	7	50		Phase angle of current phase L2	
1-1:	81	7	60		Phase angle of current phase L3	
1-1:	33	7	0		Power factor, phase L1	
1-1:	53	7	0		Power factor, phase L2	
1-1:	73	7	0		Power factor, phase L3	
1-1:	34	7	0		Frequency, phase L1	
1-1:	54	7	0		Frequency, phase L2	
1-1:	74	7	0		Frequency, phase L3	
1-1:	1	7	0		Active demand, +P, total	
1-1:	21	7	0		Active demand, +P, phase L1	
1-1:	41	7	0		Active demand, +P, phase L2	
1-1:	61	7	0		Active demand, +P, phase L3	
1-1:	2	7	0		Active demand, -P, total	
1-1:	22	7	0		Active demand, -P, phase L1	
1-1:	42	7	0		Active demand, -P, phase L2	
1-1:	62	7	0		Active demand, -P, phase L3	
1-1:	3	7	0		Reactive demand, +Q, total	
1-1:	23	7	0		Reactive demand, +Q, phase L1	
1-1:	43	7	0		Reactive demand, +Q, phase L2	
1-1:	63	7	0		Reactive demand, +Q, phase L3	
1-1:	4	7	0		Reactive demand, -Q, total	
1-1:	24	7	0		Reactive demand, -Q, phase L1	
1-1:	44	7	0		Reactive demand, -Q, phase L2	
1-1:	64	7	0		Reactive demand, -Q, phase L3	

1-1:	9	7	0		Apparent demand, +S, total	
1-1:	29	7	0		Apparent demand, +S, phase L1	
1-1:	49	7	0		Apparent demand, +S, phase L2	
1-1:	69	7	0		Apparent demand, +S, phase L3	
1-1:	10	7	0		Apparent demand, -S, total	
1-1:	30	7	0		Apparent demand, -S, phase L1	
1-1:	50	7	0		Apparent demand, -S, phase L2	
1-1:	70	7	0		Apparent demand, -S, phase L3	
1-1:	31	7	n		n. harmonic in the current L1 (n=2,3, .. 15)	
1-1:	51	7	n		n. harmonic in the current L2 (n=2,3, .. 15)	
1-1:	71	7	n		n. harmonic in the current L3 (n=2,3, .. 15)	
1-1:	32	7	n		n. harmonic in the voltage L1 (n=2,3, .. 15)	
1-1:	52	7	n		n. harmonic in the voltage L2 (n=2,3, .. 15)	
1-1:	72	7	n		n. harmonic in the voltage L3 (n=2,3, .. 15)	
1-1:	31	7	99		Total harmonic distortion, current L1	
1-1:	51	7	99		Total harmonic distortion, current L2	
1-1:	71	7	99		Total harmonic distortion, current L3	
1-1:	32	7	99		Total harmonic distortion, voltage L1	
1-1:	52	7	99		Total harmonic distortion, voltage L2	
1-1:	72	7	99		Total harmonic distortion, voltage L3	
					Load profile / log file	
1-1:	P	98			Log file	
1-1:	P	01			Load profile of billing data	
1-1:	P	02			profile of instrumentation values	

21.2 Connection diagrams

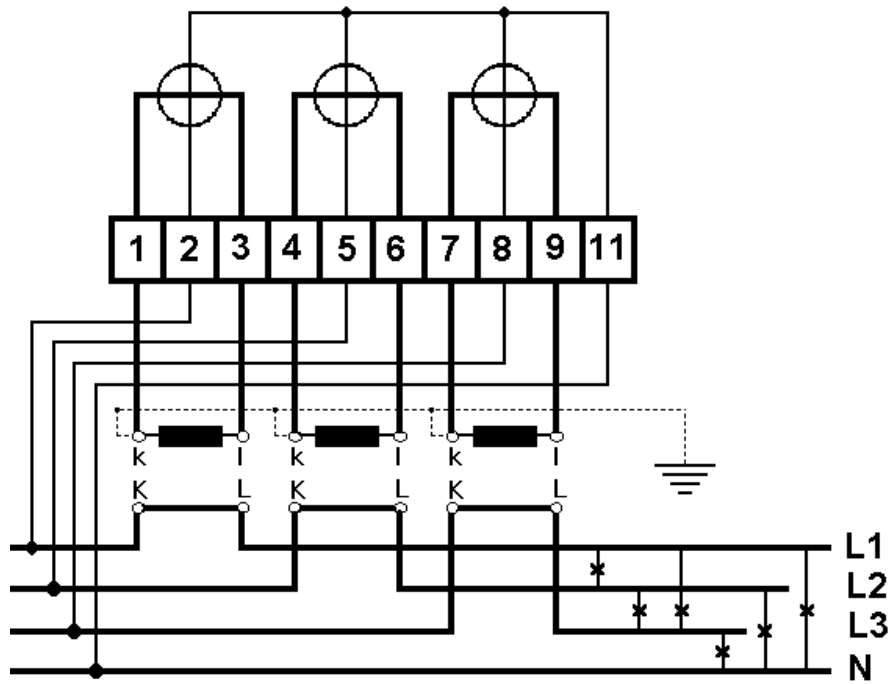

Fig. 19: 4-wire meter for CT connection

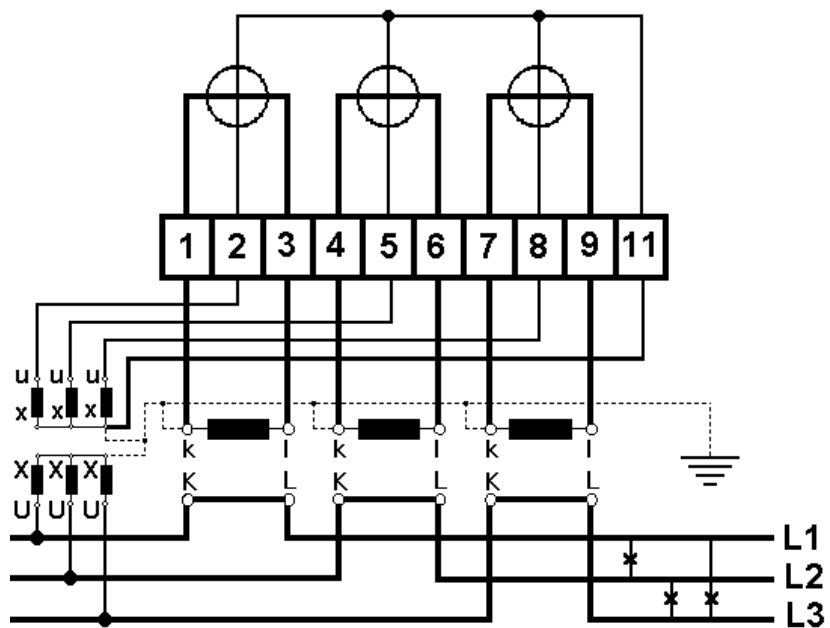

Fig. 20: 4-wire meter for CT- and VT-connection

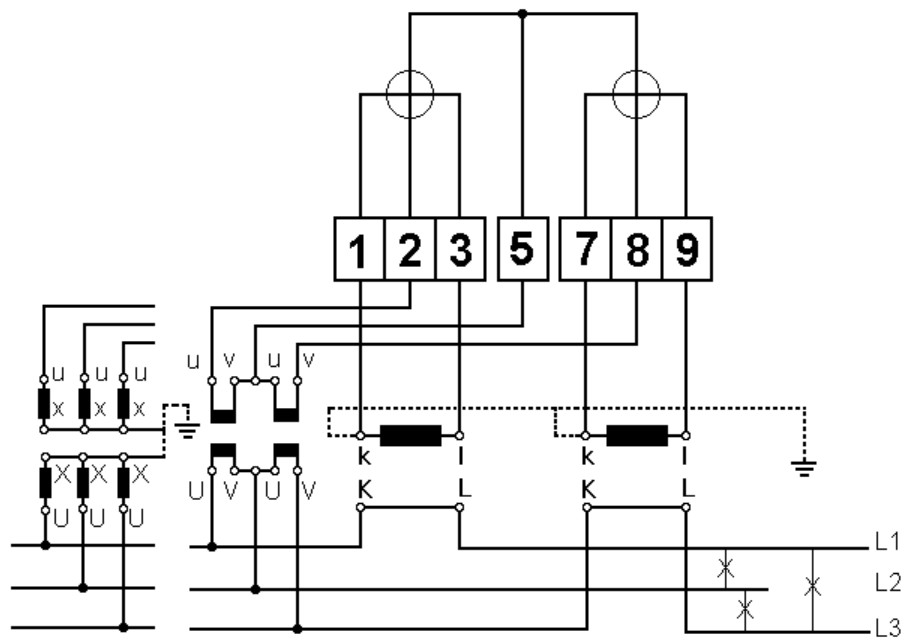

Fig.21: 3-wire meter for CT- and VT-connection

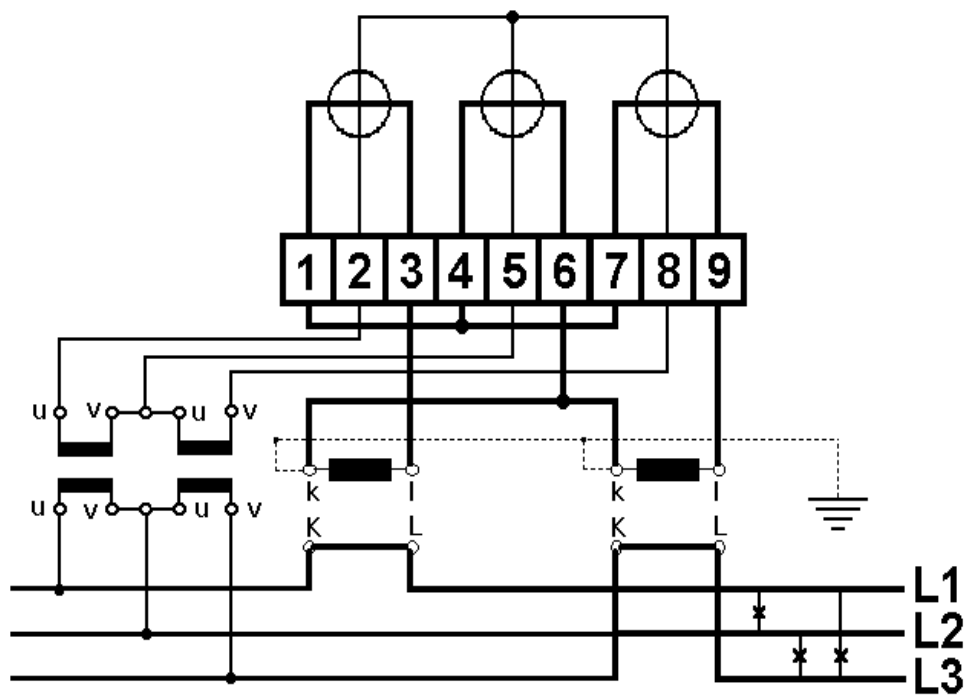

Fig. 22: 4-wire meter without connection of the neutral

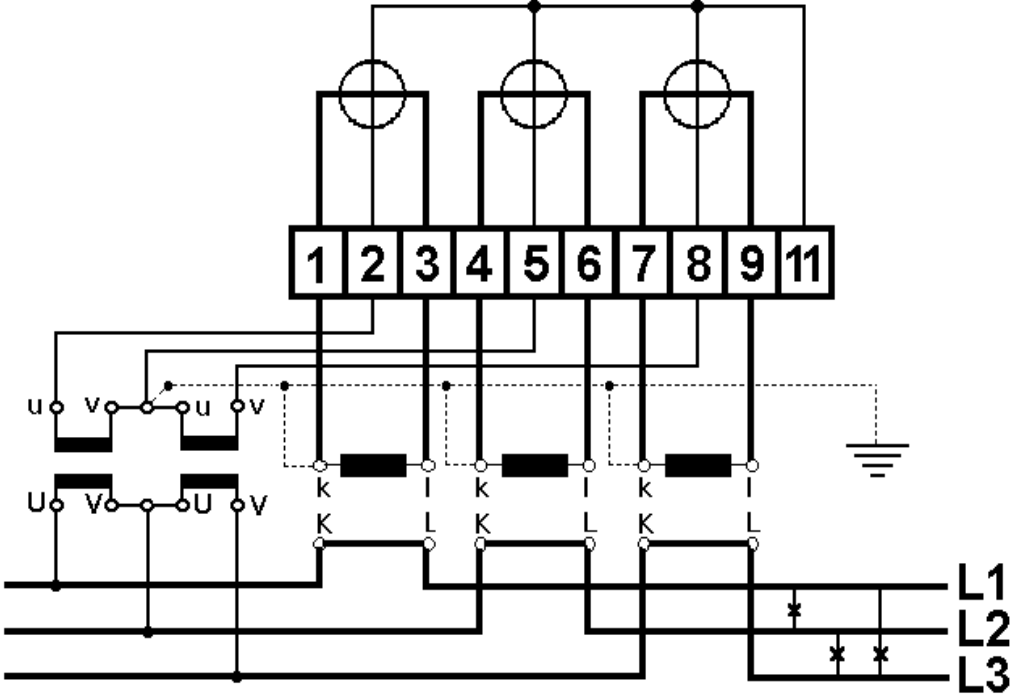

Fig. 23: 4-wire meter without connection of the neutral